

 **MONARCH WATER**

Water softener installation guide

Models:

Ultimate range - Mini Aqua HE / Midi HE / Master HE / Matrix HE (see page 2)

Ultra range - Ultra HE / Premio HE (see page 10)



Ultimate
range

Ultra
range

IMPORTANT!



Ensure your customer
registers their warranty

01986 784759
monarchwater.co.uk

A. PLANNING THE INSTALLATION - ULTIMATE RANGE (SEE PAGE 10 FOR ULTRA RANGE)

- ✓ Water pressure 1.5 (dynamic) - 5 bar (20 – 70psi)
- ✓ Ensure there is only one rising main
- ✓ Make sure you've allowed space for access to the unit - for salt filling and any future maintenance.
- ! For installation on potable water systems only
- ✓ Where possible, this should be close to the rising main.
- ✓ No matter the location, please ensure the base/floor is adequately supported.
- ! Installing in a loft/1st floor/2nd floor, etc? Place the softener in a 25-gallon tank and insulate well. Monarch take no responsibility for any water damage etc if this recommendation is not applied. The overflow on the plastic tank should be below the overflow of the softener and a minimum of 3/4" in size. **Failure to install the softener in a suitable tank will void the warranty.**
- ✓ Always observe the water byelaws
- ✓ Locate access to a drain facility
- ✓ Locate a power supply
- ! Be aware of condensation occurring in warm environments.
- ! If you are not using our Rapid-fit bypass - Tee off for mains water supply to outside tap and/or drinking water tap if applicable.
- ! Rapid-Fit bypass has a 3/8" speed fit connection for flexi tube connection to a dedicated drinking water faucet. Monarch faucet and 5mtr length of 3/8" tubing code is MW38CFK.
- ! The distance between the softener and drain needs to be as short as possible, to ensure the drain and overflow are not subject to freezing, or over 120° F/49°C.

! **DO NOT install softener at height.** This will invalidate the warranty as our technicians will not be able to safely work on the unit.

! **DO NOT Install hoses covering the main unit of the softener.** Our technicians cannot maintain/repair the unit if this is done and will invalidate warranty.

! **If using plumbers putty, please ensure you wipe away any excess.**

! **We recommend to avoid installing the softener in sunken areas/cut out areas in cupboards.** This will invalidate the warranty as our technicians need to be able to access the unit and cannot do so if it is in a sunken, unmovable area.

! **DO NOT use any heat as the softener and bypass uses plastic components.**

B. CHECK VALVE

FLUID CAT.2

Domestic ion exchange water softeners

Our Rapid-Fit bypass (optional) incorporates a high flow check valve in accordance with the fluid category 2 requirement.

If you are not using our Rapid-fit bypass for this installation, please ensure a suitable check valve is installed.

! C. DRINKING WATER FACILITY

The Regulations require that 'All premises supplied with water for domestic purposes shall have at least one tap conveniently situated for the drawing of drinking water'. Drinking water must comply with the Water Supply (Water Quality) Regulations 2000, which stipulate a maximum limit of 200 mg/l (milligrams per litre) for sodium. The provision of an unsoftened drinking water tap is essential where the hardness of the public supply and its sodium content as supplied would result in the softened water exceeding 200 mg/l milligrams per litre sodium limit.

For ion exchanged softened water, this limit will be exceeded where the water is extremely hard, i.e. above 425 mg/l as hardness (assuming zero sodium in the public supply).

The Department of Health recommends that this sodium limit should not be exceeded for infant feed preparation and for those individuals on a medically supervised low-sodium diet.

D. CHECK THE INSTALL KIT

The set consists of:

- A: 2 standard flexible hoses
- B: 4 clips
- C: Rapid-fit bypass (standard 3/4")
- D: 2.5m drain hose
- E: 1 Jubilee clip
- F: Power adapter

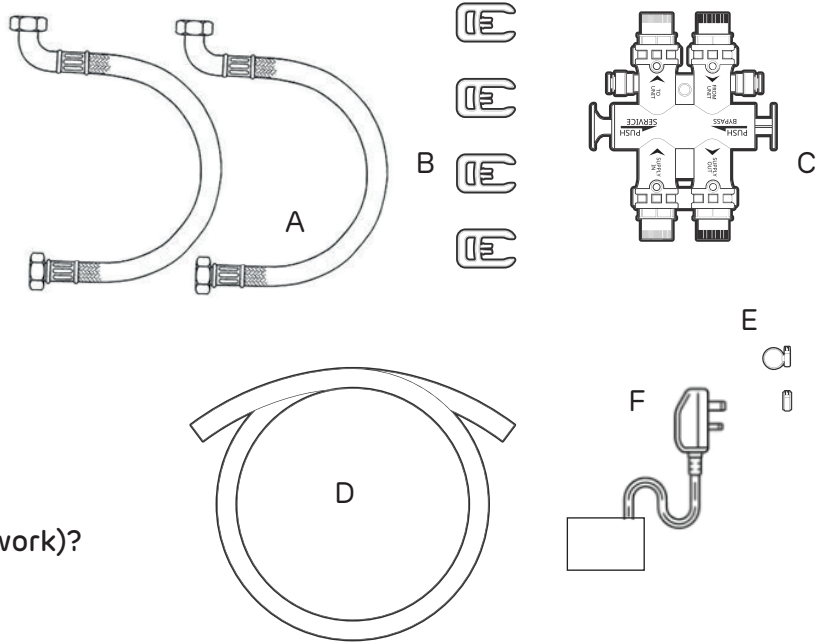

Gravity system?

Use standard hoses

Combi Boiler?

Use Maxflow hoses (code MFH006)

Pressurised/unvented system (22mm pipework)?

Use Maxflow hoses (code MFH006)

28mm supplies

A full upgrade for the softener is available - details on request - code M28UGLOHE
Rapid-Fit bypass comes with 1" connectors and Softener supplied with 1" adapters

E. WATER PRESSURE TEST

IMPORTANT - carry out a pressure check.

Low & high pressure can result in either damage to, or failure of the unit.

If daytime static water pressure exceeds 3.5 bar (50psi), a 5 bar (70 psi) pressure limiter should be fitted.

50psi daytime pressure can reach nearly 100psi at night!

Minimum dynamic pressure must exceed 1.5 bar. If in any doubt, please call our team on

01986 784 759

F. TYPICAL INSTALLATION LAYOUT

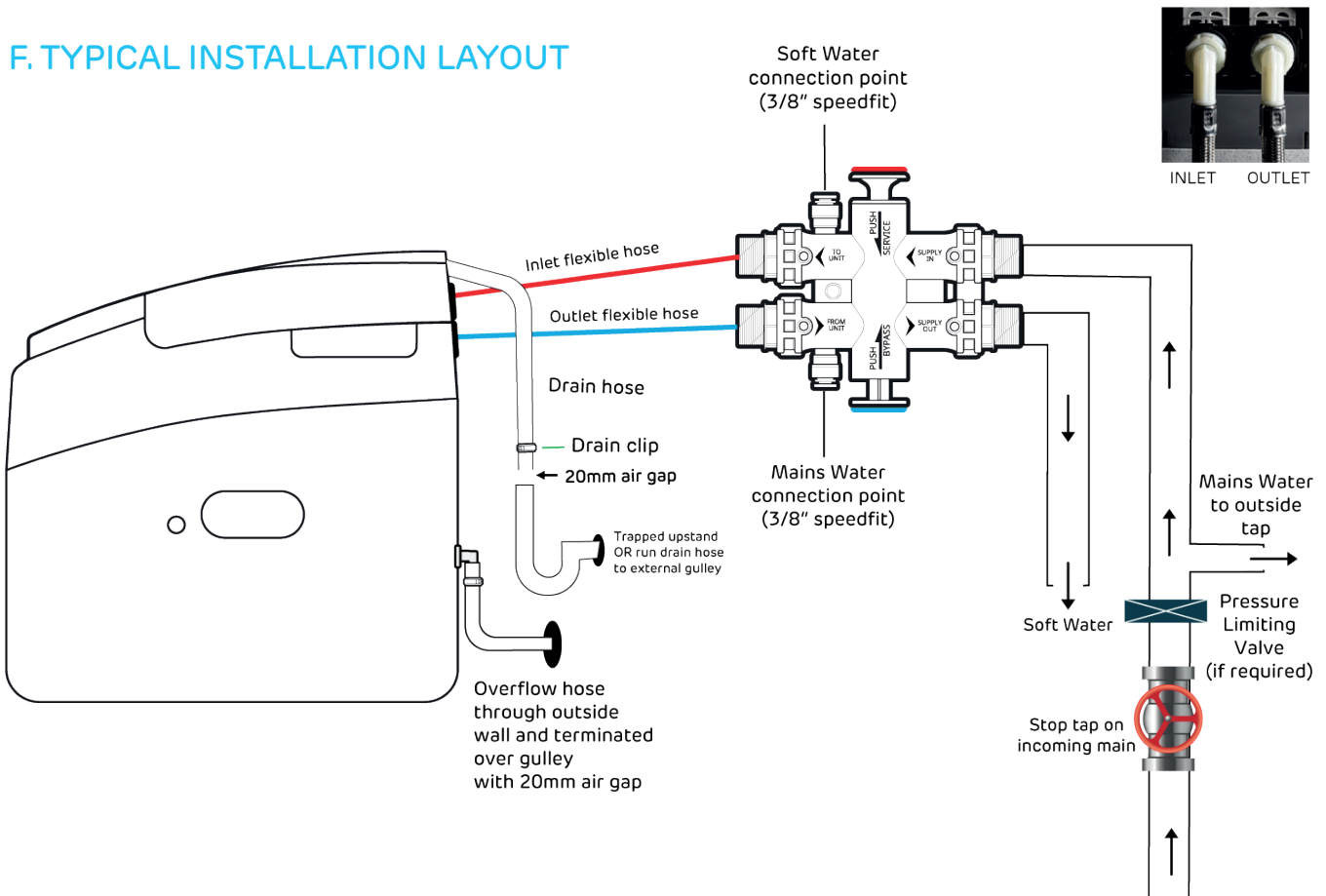

G. INSTALLING THE RAPID-FIT BYPASS

Direction arrows are embossed on the bypass as follows

Service = softener is in operation for soft water

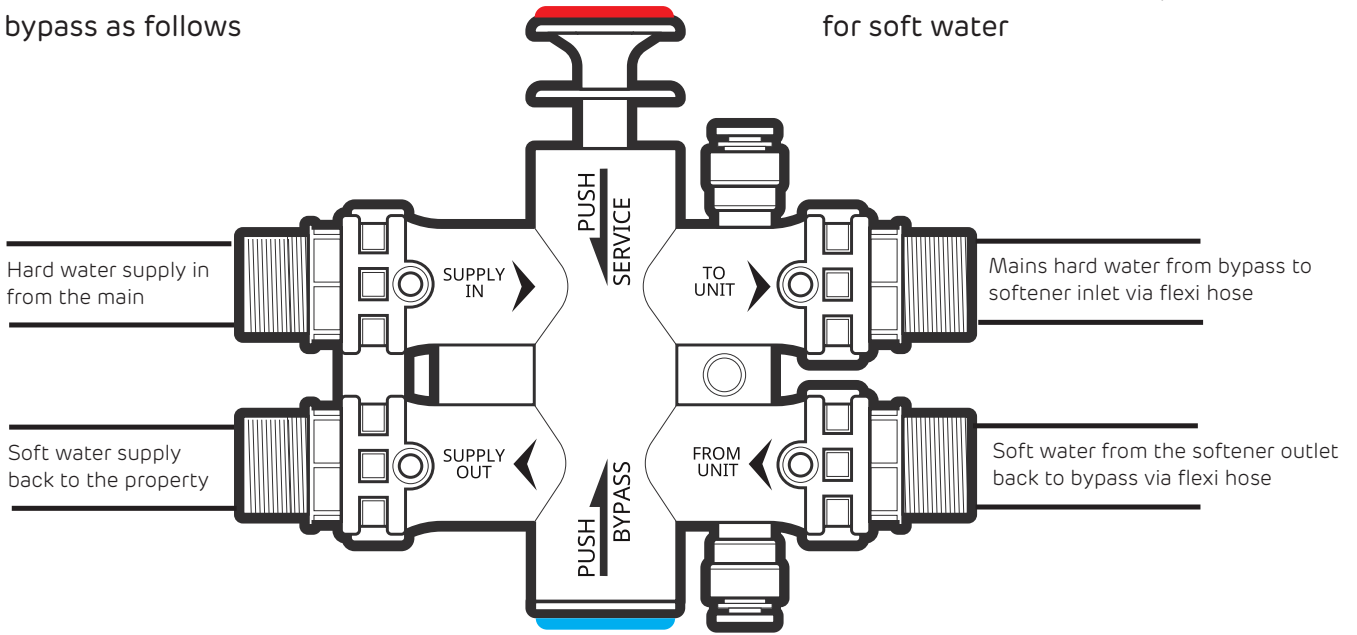

Every Rapid-Fit bypass comes with the following;
 2 x Stainless steel standard hoses (washers already inserted)
 2 x 2mm x 3/4" FI brass adaptors including 2 x 24.6mm fibre washers
 (inserted) 2 x 22mm x 15mm reducers

For Combi boilers upgrade hoses to Maxflow hoses - see image right.
 22mm Unvented/Pressurised systems, upgrade to Maxflow hoses.
 If upgrading to 28mm applications an upgrade kit (code M28UGL0HE)
 is available.

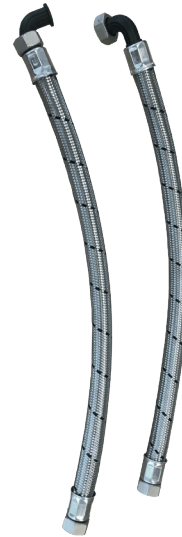

Connection of brass adaptor (22 x 3/4 FI & 28 x 1" FI) to Rapid-Fit bypass:

1. Fibre washers are pre inserted against shoulder inside brass female thread - Fig A. **IMPORTANT** - Do not use 3/4" industry standard washers here.
2. For additional security, Fernox LS-X or Loctite SI 5331 may be used. Simply apply to male thread of noryl bypass adaptor and to inside of female thread of brass fitting - Fig B. In all cases, fibre washer must be used.
3. Tighten male noryl connection into brass adaptor solidly up against fibre washer - Fig C. Remove any excess sealant inside brass/noryl adaptor assembly.
4. Place assembled connection back into bypass and fix with clip - Fig D.
5. Connect water mains supply pipe to SUPPLY IN connection
6. Repeat 1-5 above for soft water mains supply back to SUPPLY OUT connection.

FIG A



FIG B



Brass adaptor

FIG C



FIG D



H. CONNECTING THE INLET & OUTLET HOSES

Remove both salt lid and main cover (to remove rear top cover, slide/push backwards out of fixing, and lift off) to access inlet, outlet connections and the drain connection.

Remove the grey retaining clips and also BSP connection points. Connect hoses to male BSP connection points, tighten to seal, then reinsert BSP connection points back into valve body. Fit grey clips. We recommend you fit the elbow end of the hose to the inlet/outlet connection points on the softener.

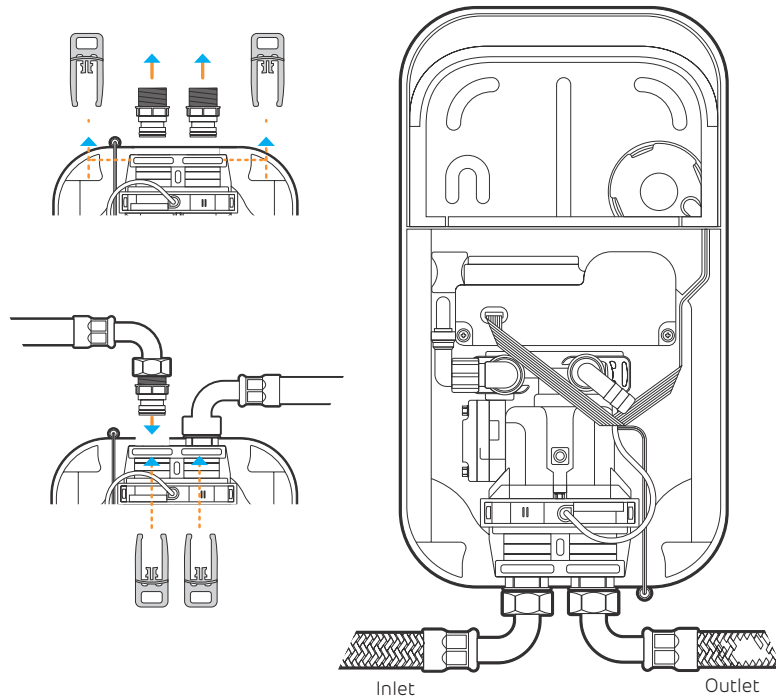

The hoses are designed to rotate once inserted in the valve body. This removes any stress/pressure placed upon the hoses when connecting them to the Rapid-Fit bypass.

Under no circumstances use washing machine hoses or plumb the softener in solid copper pipe.

I. CONNECTING THE DRAIN

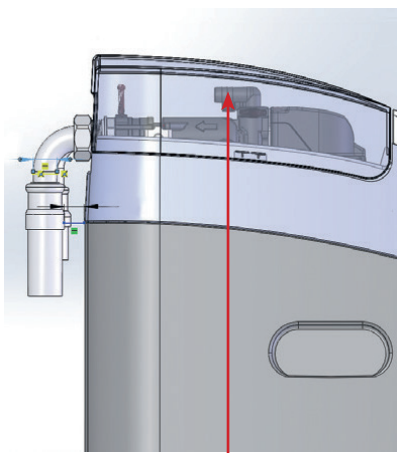

BLACK BARBED ELBOW

Using the supplied 2.5mtrs of white low pressure hose, cut the required length for the overflow and drain hose.



The white hose in the installation kit is for both the drain and the overflow.

Please cut according to length requirements, to ensure both the drain and overflow are equipped.



Connect the drain hose -

The **drain connection** is the **black barbed elbow** under the rear top cover.

Fix drain hose to black barbed elbow with jubilee clip (supplied). Run the drain hose to either an upstand or an outside drain. A minimum air gap of 20mm should exist at the end of the drain line.

Placing the drain hose uphill?



The drain can run uphill for 3ft max, as long as the water pressure is 40 psi or above.

Extending the drain hose



Connect to a 15mm copper tube, run horizontally for a max of 4m. Ensure the daytime pressure is minimum 40psi. If extending over 4m, use 22mm (or similar) copper tube. Ensure the hose is adequately fixed to the copper pipe.

! Under no circumstances should the softener drain and overflow share the same pipe. This could lead to foul smells entering the salt cabinet from the main drain via the overflow. Also, if the common drain ever gets blocked, the regen water can re-enter the softener via the overflow pipe. The drain hose must **NOT DIP** or **BE KINKED** anywhere, as this will lead to the softener overflowing.

Softened water will have no adverse effect on a septic tank.

J. CONNECTING THE OVERFLOW - IMPORTANT

The hose for the overflow should be cut from the white low pressure hose supplied with the unit.

The overflow connection is the 1/2" hose spigot on the rear right hand corner of the cabinet – no jubilee clip required. The overflow must be run downhill. Terminate the overflow immediately through an outside wall without kinks or restriction, or into a suitable trapped upstand.

A 22mm (or similar) copper protective sleeve through the outside wall will help prevent kinking of the hose.



K. FLUSH SOFTENER & TEST FOR LEAKS - IMPORTANT

1. Place Rapid-Fit bypass in **Bypass position** by pushing the plunger indicated on the bypass.

2. Open mains stopcock slowly to flush the new pipe work (5 mins). This can be done using a mains tap i.e utility room cold tap or wash basin in a bathroom - the tap may splutter.

3. Repeat step 2 but change the position of the Rapid-Fit bypass by pushing the plunger for **Service position**.

4. Check all connections for leaks.

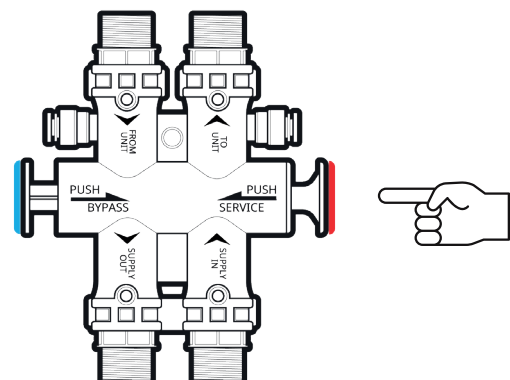
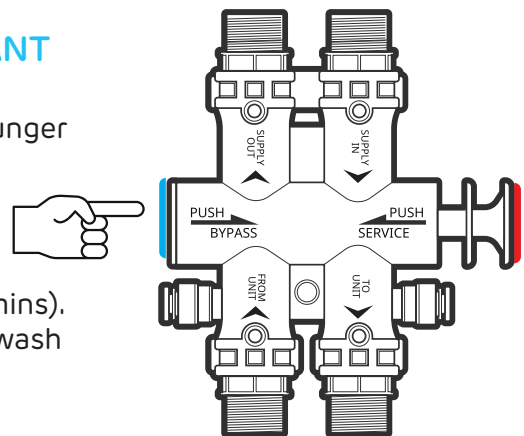

L. CONNECTING THE POWER SUPPLY

With the power off, connect the transformer – supplied – to a continuous electrical supply. Push the flying lead from the transformer into the adaptor on the lead coming from the controller.

M. OBTAIN YOUR WATER HARDNESS

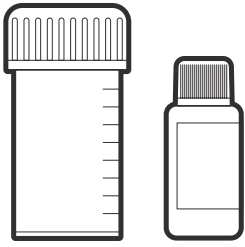



1. These instructions apply to the enclosed test kit only, read all steps before starting.
2. Let your tap (hard water) run for 1 minute and rinse the test tube well.
3. Fill the test tube up to the 10ml level.
4. Add 2 drops of the dark solution and slowly swirl the tube so the liquid mixes with the water. If the water sample contains hardness it will turn red.
5. Add the dark solution in batches of 5 drops, holding the dropper bottle at 45 degrees. Mix gently after each 5 drops.
6. Count how many drops you need until the water turns from a dark red to a dark blue/green. You need this figure for setting your water hardness in step N.

N. SETTING THE ELECTRONIC CONTROLLER

With the power on, the display shows two lines, the Model Name and also Time and Hardness. The Time and Hardness will alternate every 10 seconds. To set up the softener, you need to set both Time (24hr clock in hours and minutes) and the water Hardness as determined by the amount of drops in your water hardness test.



- SETTING THE TIME

- Wait until display says Time. If Time is correct, skip to SETTING THE HARDNESS.
- Press Up button to show flashing Hours. Please note it is a 24hr clock.
- Press Up or Down button to set Hours.
- Press  to confirm Hours.
- After confirming Hours, the display will show minutes flashing.
- Use Up and Down button to set Minutes.
- Press  to confirm Minutes.

- SETTING THE HARDNESS

- Wait until the display changes to Hardness.
- Press Up Button to show Set Hardness with no flashing.
- Use Up Button to set number as determined by your water hardness test and the correct setting referenced in the table below.
- Press  to confirm setting.

UP TO 30 DROPS	ADVANCE DISPLAY TO 30 (REC MIN SETTING)
31 - 35 DROPS	advance display to 35
36 - 40 DROPS	advance display to 40
41 - 45 DROPS	advance display to 45
46 - 50 DROPS	advance display to 50

The number you set is based on the number of drops from the water hardness test in step M.

O. FILLING THE SOFTENER WITH TABLET SALT

Fill the salt compartment with salt.

DO NOT fill salt compartment higher than the bottom of the lift handles moulded into the sides of the cabinet, as illustrated.

Add 1 litre of water into the salt compartment on initial installation only.

Please ensure the unit is kept topped up with tablet salt.

Use tablet salt only.

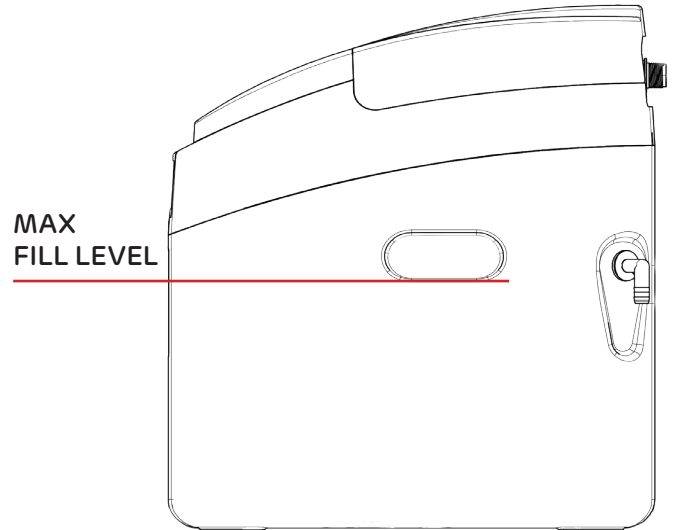

FURTHER INFORMATION

This softener uses tablet salt only.

Do not worry if your softener regenerates during the day. This is the Self Protect Programme initiating an additional mini regeneration, as the softener does not have enough soft water to last you until the next programmed regeneration of 2am.

A regeneration can last between 51 and 92 minutes depending on the model. During this time the softener goes into hard water bypass, ensuring a continuous supply of water.

A Normal regeneration is programmed to 2am, a time when little, if any, water is being used.



To change the regeneration time, simply offset the Time Setting i.e. to have the unit regenerate 2 hours later, set clock 2 hours slow- see SETTING THE TIME (page 7).

To ensure the softeners continuous operation, please do not let the salt drop below half way down in the cabinet.

Moving the softener. When moving the softener, please ensure that there is no water in the salt compartment to prevent accidental ingress into working parts of the softener.

Failure to do this may cause warranty to become void.

P. MANUAL REGENERATIONS

If you ever need to start a manual regeneration, press the left hand  button and release, the display will countdown from 15 to zero. If at any time you wish to cancel the countdown, simply press  again within the countdown period.

Q. BLENDING CONTROL - BLUE/GREEN STAINS

All our water softeners are factory set to produce water that is 100% soft. If you require slightly blended water - recommended on Combi/Condensing Boilers and in areas of hard water that have a green/blue build up in the scale - open blending control on left hand side of the main softener valve by turning slightly, until it takes 6/7 drops of the dark liquid to get a red to green colour change, as per the original water hardness test.

This blended water setting can only be done when the softener is in operation.



WHAT DO I DO WHEN I GO ON HOLIDAY?

We recommend you bypass your softener and turn off the electrics when going away on holiday. Upon your return, reset time (if necessary) and activate a manual regeneration (see step P).

BYPASSING YOUR SOFTENER

Important: Please ensure the power is turned off whilst the unit is in bypass.

To bypass your water softener simply push the **Blue bypass plunger**

To resume soft water simply push the **Red service plunger**

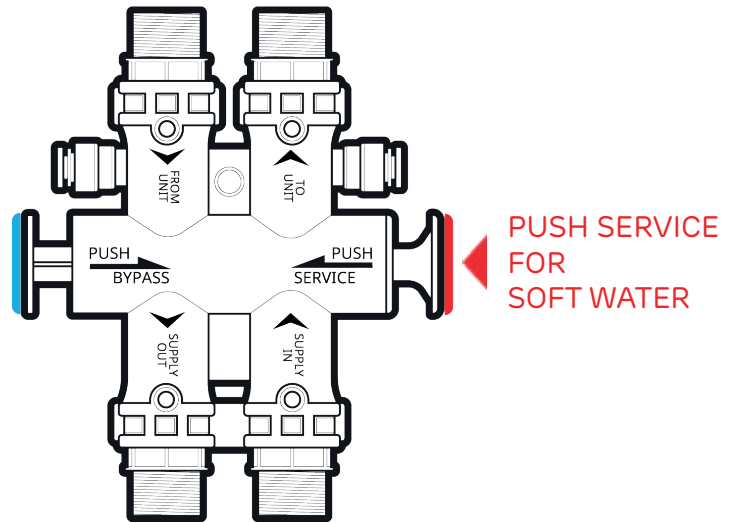
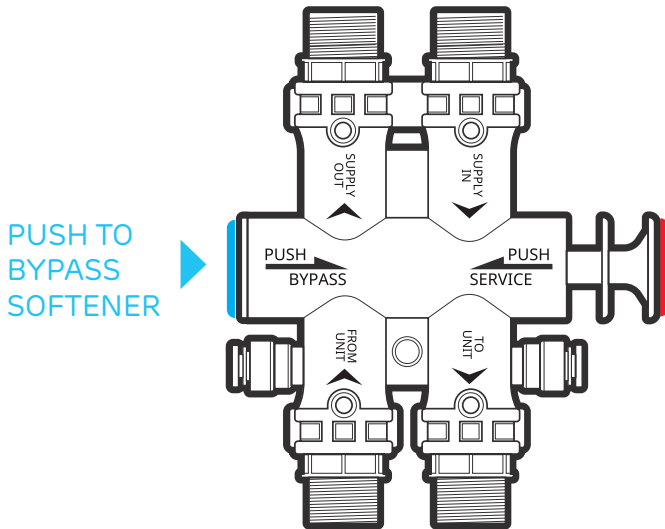

The symbol opposite means that according to United Kingdom and European Union member countries laws and regulations your product and/ or its battery shall be disposed of separately from household waste. When this product reaches its end of life, take it to a collection point designated by local authorities. The separate collection and recycling of your product and/ or its battery at the time of disposal will help conserve natural resources and ensure that it is recycled in a manner that protects human health and the environment.

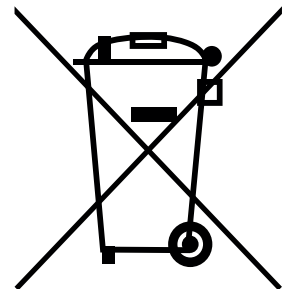

ULTRA HE & PREMIO HE INSTALL GUIDE



A. PLANNING THE INSTALLATION

- ✓ Water pressure 1.5 (dynamic) - 5 bar (20 – 70psi)
- ✓ Ensure there is only one rising main
- ✓ Make sure you've allowed space for access to the unit - for salt filling and any future maintenance.
- ! For installation on potable water systems only
- ✓ Where possible, this should be close to the rising main.
- ✓ No matter the location, please ensure the base/floor is adequately supported.
- ! Installing in a loft/1st floor/2nd floor, etc?
Place the softener in a 25-gallon tank and insulate well. Monarch take no responsibility for any water damage etc if this recommendation is not applied. The overflow on the plastic tank should be below the overflow of the softener and a minimum of 3/4" in size. Failure to install the softener in a suitable tank will void the warranty.
- ! This softener is supplied with both a battery and a plug-in transformer. The softener needs only one of these power sources to function. If you opt for the plug-in transformer, please see Page 19 in this guide when connecting the power up at step M. If you are using the supplied battery to power the unit, please follow this guide and ensure the battery is inserted when you have reached Step M in this guide.
- ! This softener has reversible valve technology, meaning the valve connector can be located on either side of the softener. If you would like to relocate the valve connection, please scan the QR code for instructions -
- ✓ Always observe the water byelaws
- ✓ Locate access to a drain facility
- ✓ Locate a power supply if needed
- ! Be aware of condensation occurring in warm environments.
- ! If you are not using our Rapid-fit bypass - Tee off for mains water supply to outside tap and/or drinking water tap if applicable.
- ! Rapid-Fit bypass has a 3/8" speed fit connection for flexi tube connection to a dedicated drinking water faucet. Monarch faucet and 5mtr length of 3/8" tubing code is MW38CFK.
- ! The distance between the softener and drain needs to be as short as possible, to ensure the drain and overflow are not subject to freezing, or over 120° F/49°C.



- ! DO NOT install softener at height. This will invalidate the warranty as our technicians will not be able to safely work on the unit.
- ! DO NOT Install hoses covering the main unit of the softener. Our technicians cannot maintain/repair the unit if this is done and will invalidate warranty.
- ! If using plumbers putty, please ensure you wipe away any excess.

- ! We recommend to avoid installing the softener in sunken areas/cut out areas in cupboards. This will invalidate the warranty as our technicians need to be able to access the unit and cannot do so if it is in a sunken, unmovable area.
- ! DO NOT use any heat as the softener and bypass uses plastic components

B. CHECK VALVE

FLUID CAT.2

Domestic ion exchange water softeners

Our Rapid-Fit bypass (optional) incorporates a high flow check valve in accordance with the fluid category 2 requirement.

If you are not using our Rapid-fit bypass for this installation, please ensure a suitable check valve is installed.

! C. DRINKING WATER FACILITY

The Regulations require that 'All premises supplied with water for domestic purposes shall have at least one tap conveniently situated for the drawing of drinking water'. Drinking water must comply with the Water Supply (Water Quality) Regulations 2000, which stipulate a maximum limit of 200 mg/l (milligrams per litre) for sodium. The provision of an unsoftened drinking water tap is essential where the hardness of the public supply and its sodium content as supplied would result in the softened water exceeding 200 mg/l milligrams per litre sodium limit.

For ion exchanged softened water, this limit will be exceeded where the water is extremely hard, i.e. above 425 mg/l as hardness (assuming zero sodium in the public supply).

The Department of Health recommends that this sodium limit should not be exceeded for infant feed preparation and for those individuals on a medically supervised low-sodium diet.

D. CHECK THE INSTALL KIT

The set consists of:

- A: 2 Maxflow hoses
- B: 4 clips
- C: Rapid-fit bypass (standard 3/4")
- D: 2.5m drain hose
- E: 2 rubber/fibre washers
- F: 1 Jubilee clip
- G: Power adapter
- H: 9V lithium battery

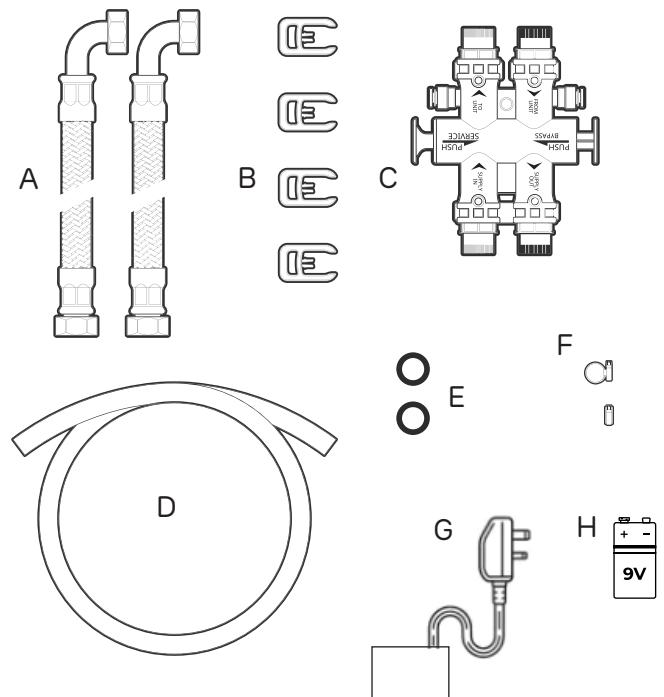

28mm supplies

A full upgrade for the softener is available - details on request - code M28UGLOHE
 Rapid-Fit bypass comes with 1" connectors and Softener supplied with 1" adapters.

E. WATER PRESSURE TEST

IMPORTANT - carry out a pressure check.

Low & high pressure can result in either damage to, or failure of the unit.

If daytime static water pressure exceeds 3.5 bar (50psi), a 5 bar (70 psi) pressure limiter should be fitted. 50psi daytime pressure can reach nearly 100psi at night!

Minimum dynamic pressure must exceed 1.5 bar. If in any doubt, please call our team on 01986 784 759.

F. TYPICAL INSTALLATION LAYOUT

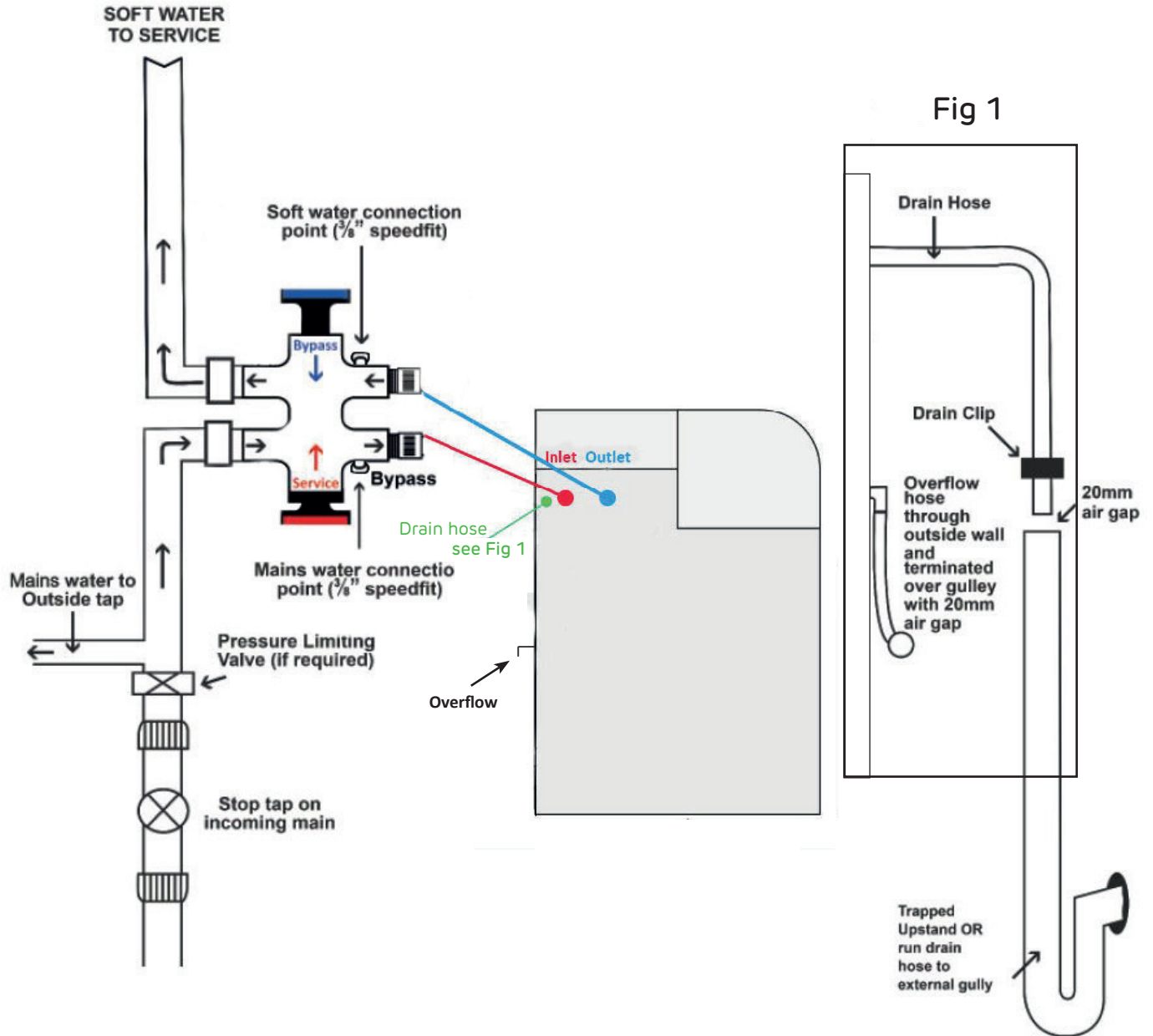

G. INSTALLING THE RAPID-FIT BYPASS

Direction arrows are embossed on the bypass as follows

Service = softener is in operation for soft water

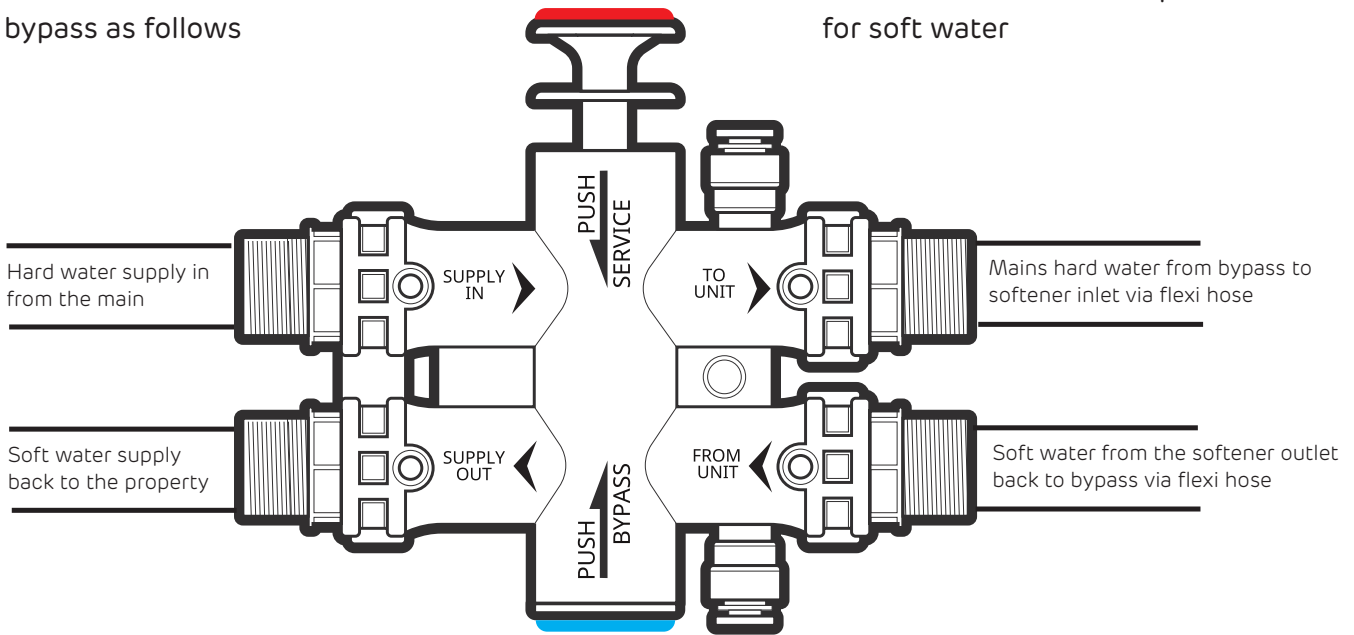

Every Rapid-Fit bypass comes with the following;

2 x Stainless steel standard hoses (washers already inserted)

2 x 2mm x 3/4" FI brass adaptors including 2 x 24.6mm fibre washers (inserted) 2 x 22mm x 15mm reducers

If upgrading to 28mm applications an upgrade kit (code M28UGL0HE) is available.

Connection of brass adaptor (22 x 3/4 FI & 28 x 1" FI) to Rapid-Fit bypass:

1. Fibre washers are pre inserted against shoulder inside brass female thread - Fig A. **IMPORTANT** - Do not use 3/4" industry standard washers here.
2. For additional security, Fernox LS-X or Loctite SI 5331 may be used. Simply apply to male thread of noryl bypass adaptor and to inside of female thread of brass fitting - Fig B. In all cases, fibre washer must be used.
3. Tighten male noryl connection into brass adaptor solidly up against fibre washer - Fig C. Remove any excess sealant inside brass/noryl adaptor assembly.
4. Place assembled connection back into bypass and fix with clip - Fig D.
5. Connect water mains supply pipe to SUPPLY IN connection
6. Repeat 1-5 above for soft water mains supply back to SUPPLY OUT connection.

FIG A



FIG B



Brass adaptor

FIG C



FIG D



H. CONNECTING THE INLET & OUTLET HOSES

Remove both salt lid and main cover to access inlet and outlet connections.

Remove grey retaining clips and BSP connection points (indicated red and blue below). Connect inlet hose to male BSP connection point (indicated red below) and connect outlet hose to BSP connection (indicated blue below), using supplied washers and tighten to seal.

Then reinsert BSP connection points back into valve body. Fit grey clips.

Inlet & Outlet connections &
drain connection

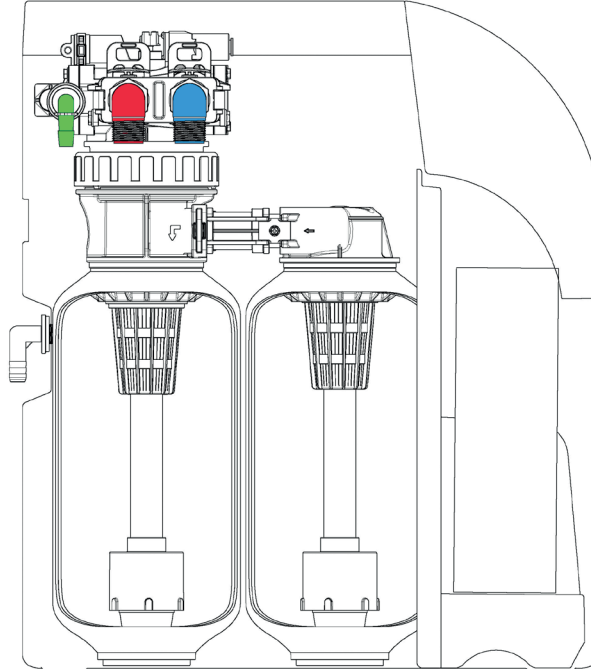

The hoses are designed to rotate once inserted in the valve body. This removes any stress/pressure placed upon the hoses when connecting them to the Rapid-Fit bypass.

Under no circumstances use washing machine hoses or plumb the softener in solid copper pipe.

I. CONNECTING THE DRAIN

- ⚠ Using the supplied 2.5mtrs of white low pressure hose, cut the required length for the overflow and drain hose.
The white hose in the installation kit is for both the drain and the overflow.
Please cut according to length requirements, to ensure both the drain and overflow are equipped.
- ⚠ Connect the drain hose -
The drain connection is the white elbow on the side (pictured green above). Fix drain hose to white barbed elbow with jubilee clip (supplied).
Run the drain hose to either an upstand or an outside drain. A minimum air gap of 20mm should exist at the end of the drain line.

Placing the drain hose uphill?

- ⚠ The drain can run uphill for 3ft max, as long as the water pressure is 40 psi or above.

Extending the drain hose

- ⚠ Connect to a 15mm copper tube, run horizontally for a max of 4m. Ensure the daytime pressure is minimum 40psi.
If extending over 4m, use 22mm (or similar) copper tube. Ensure the hose is adequately fixed to the copper pipe.

! Under no circumstances should the softener drain and overflow share the same pipe. This could lead to foul smells entering the salt cabinet from the main drain via the overflow. Also, if the common drain ever gets blocked, the regen water can re-enter the softener via the overflow pipe. The drain hose must NOT DIP or BE KINKED anywhere, as this will lead to the softener overflowing.

Softened water will have no adverse effect on a septic tank.

J. CONNECTING THE OVERFLOW - IMPORTANT

The hose for the overflow should be cut from the white low pressure hose supplied with the unit.

The overflow connection is the 1/2" hose spigot on the rear of the cabinet - no jubilee clip required.

The overflow must be run downhill and terminate immediately through an outside wall without kinks or restriction.

A 22mm copper protective sleeve through the outside wall will help prevent kinking of the hose.

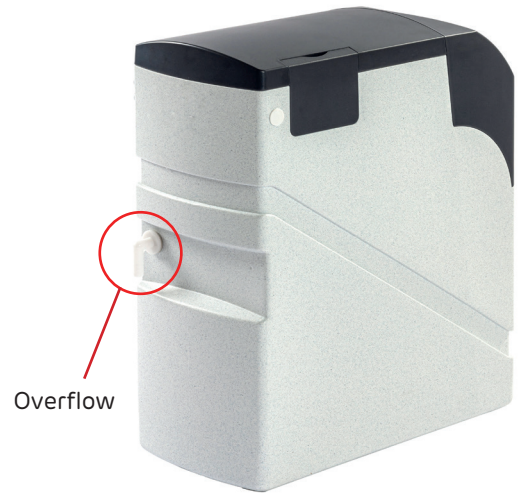

K. TEST FOR LEAKS

1. Place Rapid-Fit bypass in **Bypass position** by pushing the plunger indicated on the bypass.

2. Open mains stopcock slowly to flush the new pipe work. This can be done using a mains tap i.e utility room cold tap or wash basin in a bathroom - the tap may splutter.

3. Repeat step 2 but change the position of the Rapid-Fit bypass by pushing the plunger for **Service position**.

4. Check all connections for leaks.

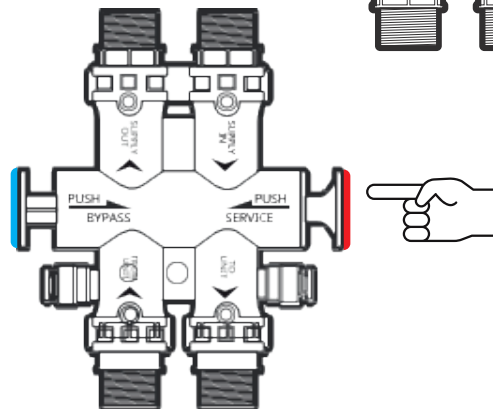
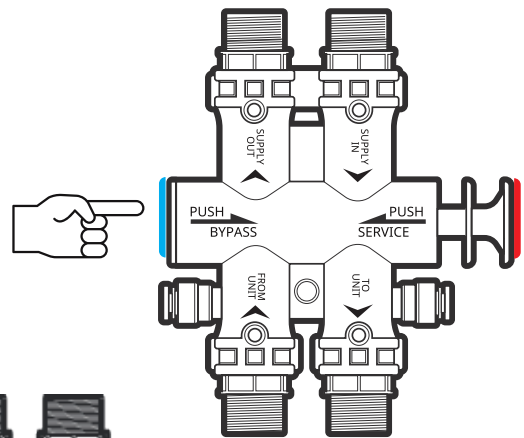

L. OBTAIN YOUR WATER HARDNESS



1. These instructions apply to the enclosed test kit only, read all steps before starting.
2. Let your tap (hard water) run for 1 minute and rinse the test tube well.
3. Fill the test tube up to the 10ml level.
4. Add 2 drops of the dark solution and slowly swirl the tube so the liquid mixes with the water. If the water sample contains hardness it will turn red.
5. Add the dark solution in batches of 5 drops, holding the dropper bottle at 45 degrees. Mix gently after each 5 drops.
6. Count how many drops you need until the water turns from a dark red to a dark blue/green. You need this figure for setting your water hardness in step M.

M. CONNECTING THE POWER & SETTING THE ELECTRONIC CONTROLLER

If using battery power, ensure battery (supplied) is fitted into the battery compartment, alternatively, if using the plug-in transformer please see Page 19. The softener display will say WELCOME as soon as battery or transformer is connected.

The Display shows both the Time and Hardness. The Time and Hardness will alternate every 10 seconds. To finalise commissioning of the softener, you need to set both Time (24hr clock in hours and minutes) and the water Hardness as determined by the number of drops in your water hardness test.

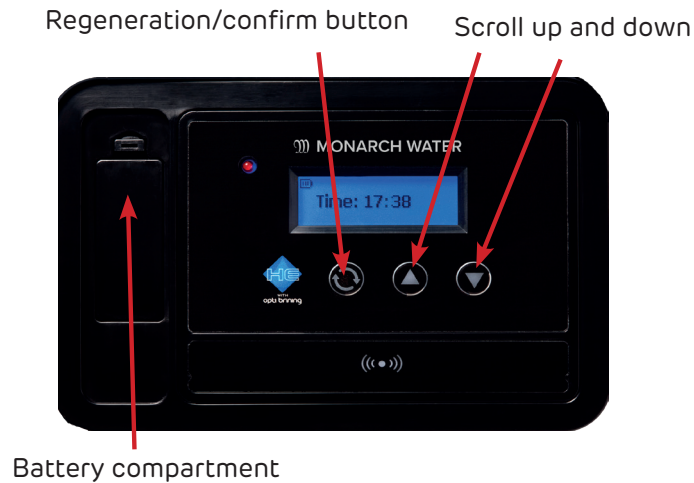

- SETTING THE TIME

Wait until display says Time of Day. If Time of Day is correct, skip to SETTING THE HARDNESS.

Press Up button to show flashing Hours. Please note it is a 24hr clock.

Press Up or Down button to set Hours.

Press  to confirm Hours.

After confirming Hours, the display will show minutes flashing.

Use Up and Down button to set Minutes.

Press  to confirm Minutes.

- SETTING THE HARDNESS

Wait until the display changes to Hardness.

Press Up Button to show Set Hardness with no flashing.

Use Up Button to set number as determined by your water hardness test and the correct setting referenced in the table below.

Press  to confirm setting.

You have finished the programming.

The display will now automatically revert back to the alternating display. After 30 seconds the display will go to sleep. This helps prolong the life of the battery (if using).

If at any time you want to reset a figure, press the up or down arrow to turn the display back on. Then wait until the display changes to the relevant setting and then reprogramme as required.

UP TO 30 DROPS	ADVANCE DISPLAY TO 30 (REC MIN SETTING)
31 - 35 DROPS	advance display to 35
36 - 40 DROPS	advance display to 40
41 - 45 DROPS	advance display to 45
46 - 50 DROPS	advance display to 50

The number you set is based on the number of drops from the water hardness test in step L.

N. FILLING THE SOFTENER WITH TABLET SALT

The Ultra HE can use either tablet or block salt.
The Premio HE must use tablets only.

Add 4 litres of water into the salt compartment on initial installation only.

Please ensure the unit is kept topped up with salt.

When using tablet salt, please do not fill salt compartment 100% full, kindly leave a gap of 30mm between the top of the salt and the front of the salt compartment - please use the image opposite for guidance.

TABLET SALT
MAX FILL LEVEL

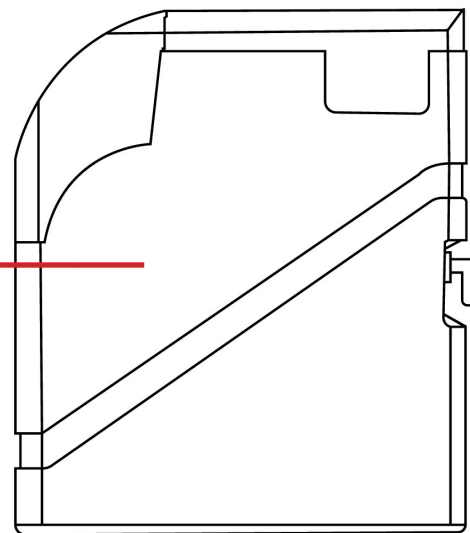



IMPORTANT INFORMATION

Do not worry if your softener regenerates during the day. This is the built in CPP (Customer Protect Programme) initiating an additional mini regeneration, as the softener does not have enough soft water to last you until the next programmed regeneration of 2am. A regeneration typically lasts 42 minutes for the Ultra HE and 63 minutes for the Premio HE. During this time the softener goes into hard water bypass, ensuring a continuous supply of water. A Normal regeneration is programmed to 2am, a time when little, if any, water is being used.

To change the regeneration time, simply offset the Time Setting i.e., to have the unit regenerate 2 hours later, set clock 2 hours slow - see SETTING THE TIME (Page 16).

If using the battery to power the unit, the battery life will depend on how many regenerations are activated, depending on water use. Therefore, please ensure you change the battery when indicated (by low battery indicator on the display screen, and when the audible alarm sounds) or at least annually using a 9V lithium battery (6LR61).

O. MANUAL REGENERATIONS

If you ever need to start a manual regeneration, press the left hand  button and release, the display will countdown from 15 to zero. If at any time you wish to cancel the countdown, simply press  again within the countdown period.

P. BLENDING CONTROL - BLUE/GREEN STAINS

All our water softeners are factory set to produce water that is 100% soft. If you require slightly blended water - recommended on Combi/ Condensing Boilers and in areas of hard water that have a green/blue build up in the scale - open blending control on left hand side of the main softener valve by turning slightly, until it takes 6/7 drops of the dark liquid to get a red to green colour change, as per the original water hardness test.



This blended water setting can only be done when the softener is in operation.

WHAT DO I DO WHEN I GO ON HOLIDAY?

We recommend you bypass your softener and turn off the electrics when going away on holiday. Upon your return, reset time (if necessary) and activate a manual regeneration (see step O).

BYPASSING YOUR SOFTENER

Important: Please ensure the power is turned off whilst the unit is in bypass.

To bypass your water softener simply push the **Blue bypass plunger**

To resume soft water simply push the **Red service plunger**

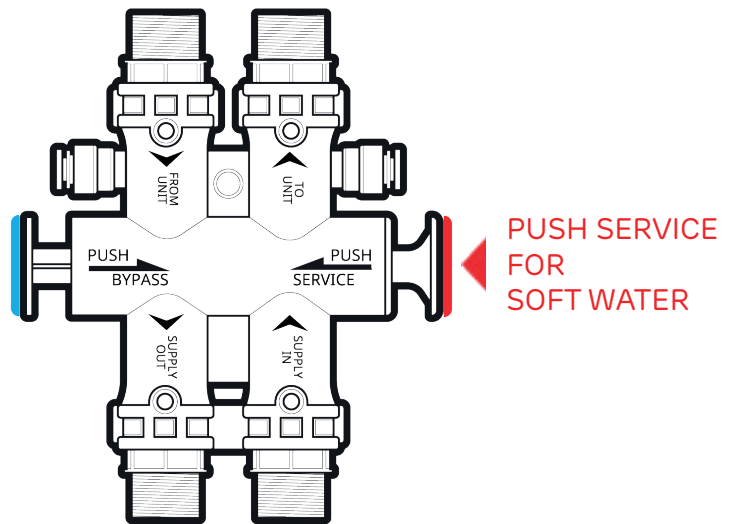
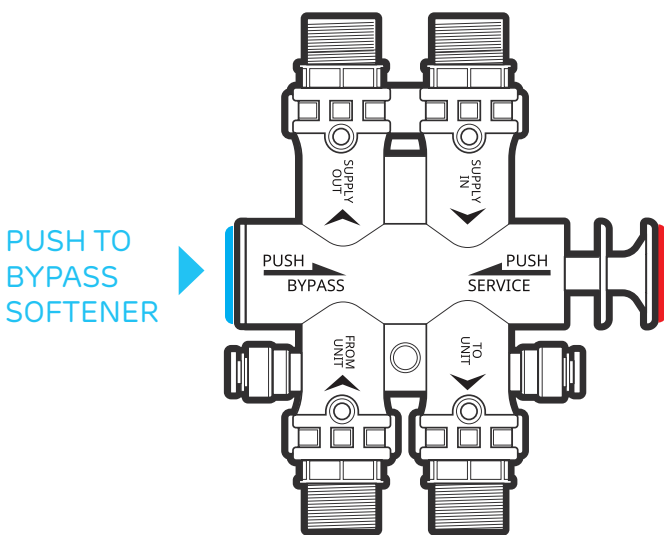

This symbol opposite means that according to United Kingdom and European Union member countries laws and regulations your product and/ or its battery shall be disposed of separately from household waste. When this product reaches its end of life, take it to a collection point designated by local authorities. The separate collection and recycling of your product and/ or its battery at the time of disposal will help conserve natural resources and ensure that it is recycled in a manner that protects human health and the environment.

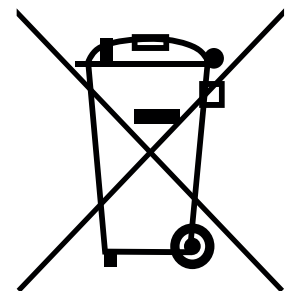

TRANSFORMER INSTRUCTIONS

1.



Remove top cover and salt lid

2.



Slide the display PCB housing up out of the cabinet

3.

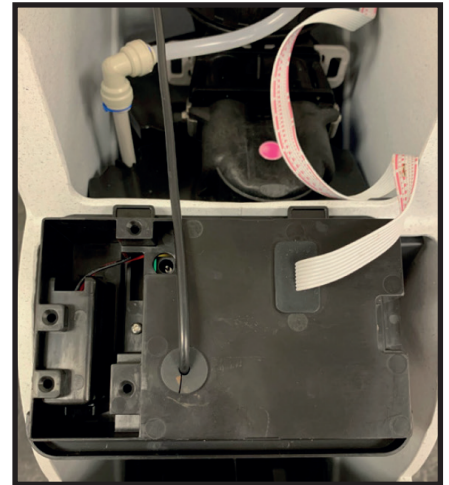

Remove the piece of rubber on the back

4.

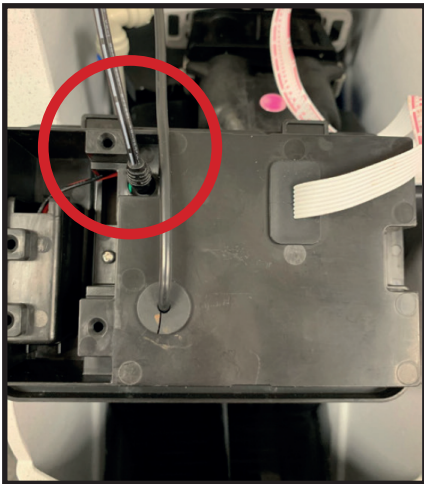

Connect the transformer to the connection point at the bottom of the PCB housing

5.



Slide the PCB housing back in to place

6.



Turn the transformer on, there should be a small transformer symbol on the top left hand corner, Return the top cover and salt lid to their original positions

We're here to help

If you need more info or advice,
contact our team by phone or via our
website.

