

 MONARCH WATER

CAPRICORN

WELLBEING™

INSTALL GUIDE
REVERSE OSMOSIS MACHINE



EVOLUTION SINCE 1964

IMPORTANT READ BEFORE COMMENCING INSTALLATION

ALL CAPRICORN UNITS MUST BE INSTALLED BY A COMPETENT PERSON.

/ UNIT SPECIFICATIONS

Voltage and Frequency: 110V-240V 50Hz/60Hz
 Wattage: 25W-36W
 RO Element Capacity: 50/75/100/125/150GPD
 Tank Capacity : 3.2G Steel or 3.0G Plastic
 Inlet TDS: ≤ 250ppm
 Chlorine Level: ≤ 0.2ppm
 Average RO Rejection Rate: 98%
 Inlet Water Pressure (min/Max): 14.5 - 43.5 psi
 Inlet
 Water Temperature (min/Max): 5 ° C - 45 ° C
 Flush Type (model dependent): Auto or Manual

/ CONTENTS OF PACKAGE

Reverse Osmosis Unit - 1 pc
 Housing Wrench - 2 pcs
 Food Grade Tubing - 4 pcs (Red, White, Yellow, Blue)
 Faucet - 1 pc
 Accessories- Drain Clamp, Tee Fitting,
 Ball Valve, Feed Water Valve RO Membrane -1 pcs
 Manual -1 pcs

/ RECOMMENDED TOOLS NEEDED FOR INSTALLATION

Knife Seal tape
 Electric drill Monkey wrench
 Hammer Scissors

/ 5 STAGE FILTRATION

The stages and their functions are outlined below

- First Stage / Spun PP Filter -removes larger particles suspended in water.
- Second Stage / Granular Carbon Filter - removes organics, chlorine, odour, and turbidity.
- Third Stage / Block Carbon Filter - further removes any organics, chlorine, odour and turbidity.
- Fourth Stage / RO Membrane -removes bacteria, heavy metals, dissolved matter, and salinity.
- Fifth Stage / Inline Carbon Filter (post filter) -adjusts the taste of treated water.

/ BEFORE YOU START

- Read through all instructions before beginning installation and using this system. Follow all steps exactly or risk damaging system/incorrect operation.
- This system contains filters that need to be replaced at certain intervals. Replacement intervals will vary according to use, please contact your local dealer for details.
- Please install system on potable water only. On non-potable water sources, system will not function properly and additional pre-treatment may be needed.
- Ensure source water pressure is between 14.5 - 43.5 psi. If source water pressure exceeds maximum pressure a pressure reduction valve may be needed, consult your local dealer.
- Ensure source water temperature is between 5°C - 45°C. System will not function properly if these temperatures are exceeded. DO NOT INSTALL ON HOT WATER SOURCE.
- Do not use system on noticeably contaminated water such raw sewage or well water.
- This unit operates on 110V-240V power. Please ensure you are using the correct power source.

/ WARNING

- Do not disassemble, open, or modify this unit. Tampering with the unit may cause failure or damage and will void warranty.
- Do not cover the unit, as this will prevent proper heat dissipation and can cause damage or fire.
- Do not place objects on top of the unit as this may cause damage to the unit and may cause leaking.
- Follow all recommended operating pressures and temperature, failure to do so will cause damage to the unit and void warranty.

/ HOW YOUR SYSTEM WORKS

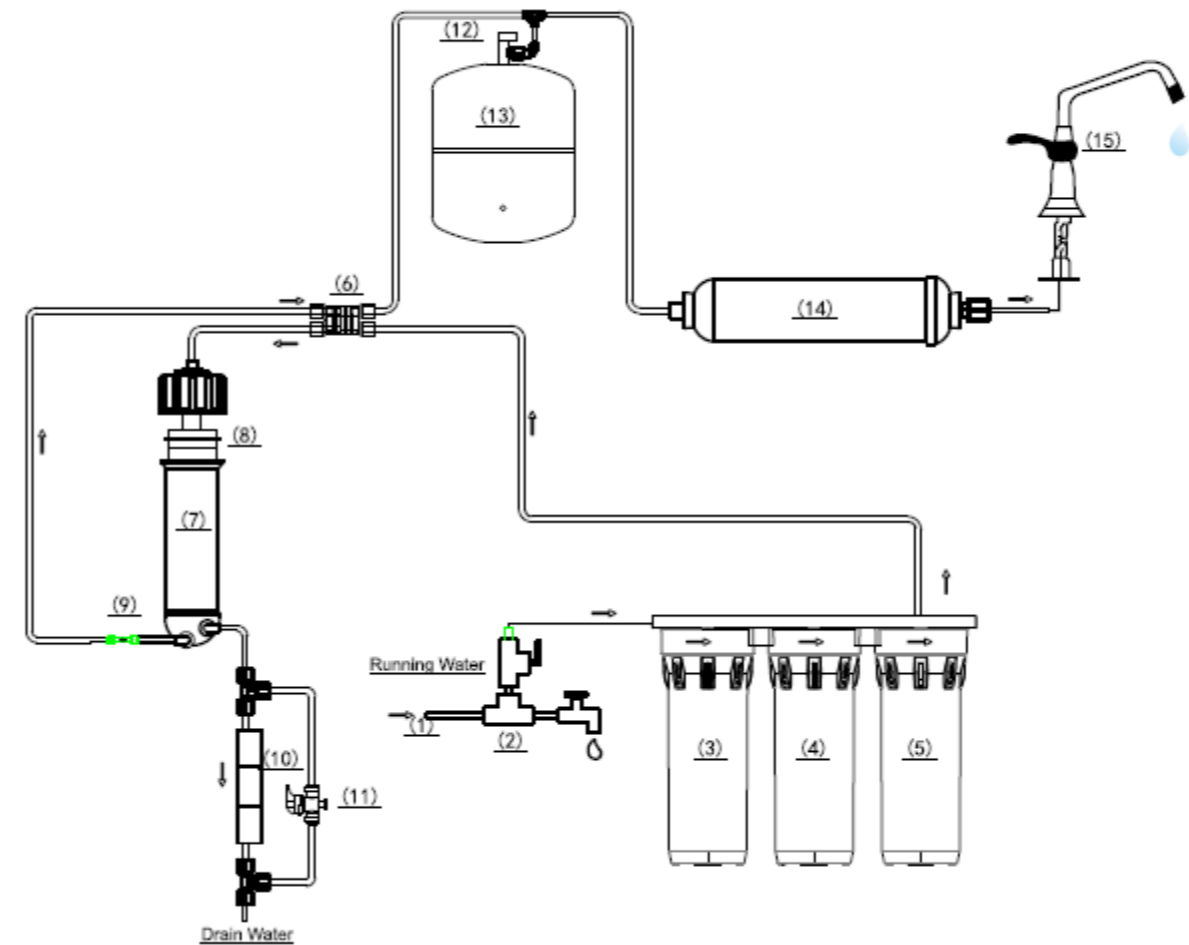
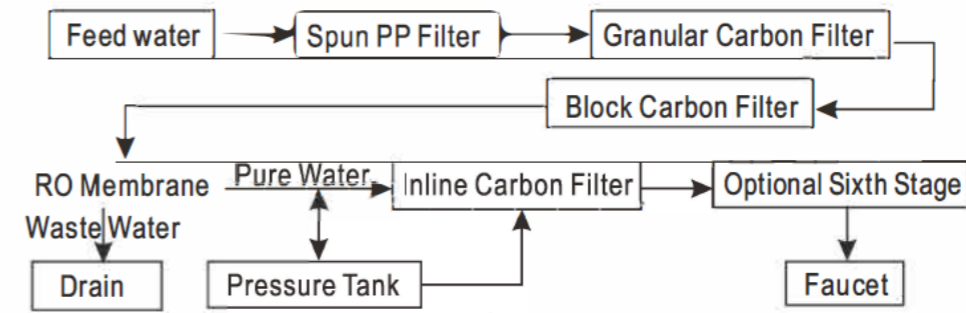

- | | | |
|---------------------------|--------------------------|------------------------|
| 1. Feed Water Valve | 2. Tee Fitting | 3. PP Spun Fiber |
| 4. Granular Carbon Filter | 5. Block Carbon Filter | 6. Auto Shut Off Valve |
| 7. Membrane Housing | 8. RO Membrane | 9. Check Valve |
| 10. Drain Restrictor | 11. By-pass flush Valve | 12. Ball Valve |
| 13. Pressure Tank | 14. Inline Carbon Filter | 15. Faucet |

/ UNIT PLACEMENT

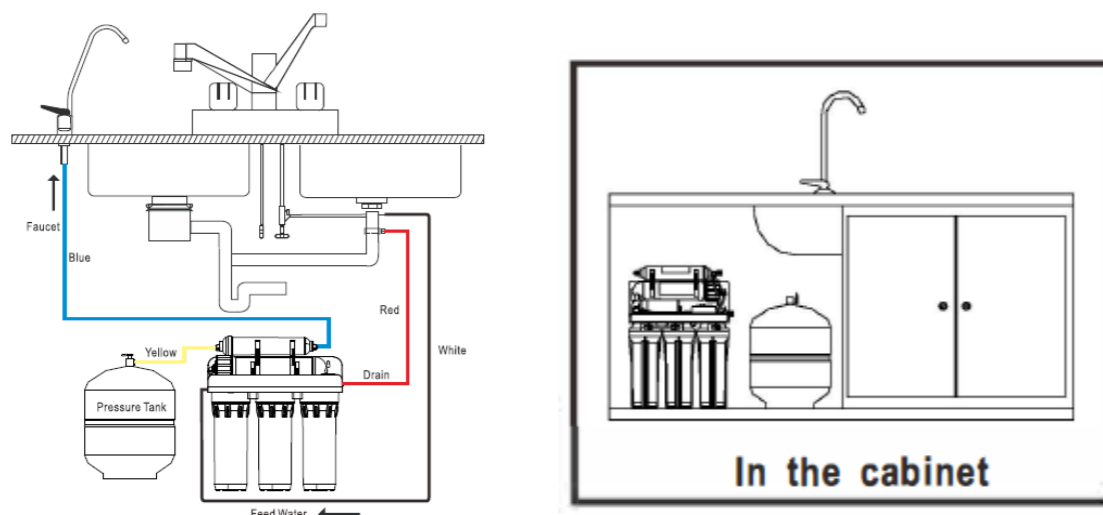

The unit can be placed flat or upright and on top, inside, or under the cabinet. Feed Water connection should be as close as possible to unit. However, if due to space or other limitations, this unit can be placed where it is convenient.

When choosing a location for the unit, remember to have easy access to cold water line, drain pipe, power outlet, and enough room to change filters. All components and tubing should be located in an area not exposed to freezing temperatures or direct sunlight.

NOTE: All components and tubing should be located in an area not exposed to freezing temperatures or direct sunlight.

/ DRAIN CLAMP INTRODUCTION

A Drain Clamp is used to make a wastewater connection with the drain under the sink, and is designed to fit around a standard 40mm OD drainpipe. The drain saddle valve should always be installed before (above) the p-trap and on a vertical or horizontal drain. To avoid clogging the drain line with debris, do not install the drain saddle near a garbage disposal.

/ DRAIN CLAMP INSTALLATION

Position drain clamp on drain pipe above the drain trap and tighten securely. Using the drain clamp as a guide, drill a 6mm hole, enough for the 1/4" tubing to pass, through one side of the drain pipe. **DO NOT** drill through both sides. Connect **Red Waste Water Tubing** from unit to Drain Clamp.

/ NOTE

When cutting the tubing make clean, square, cuts, failing to do so result in poor connection and possible leaks.

/ WARNING

The lowest point of the line should be the point of connection to the Drain Clamp. There should be no sag in the line as this may cause excessive noise as the reject water is flowing to drain.

/ DRAIN CLAMP ASSEMBLY

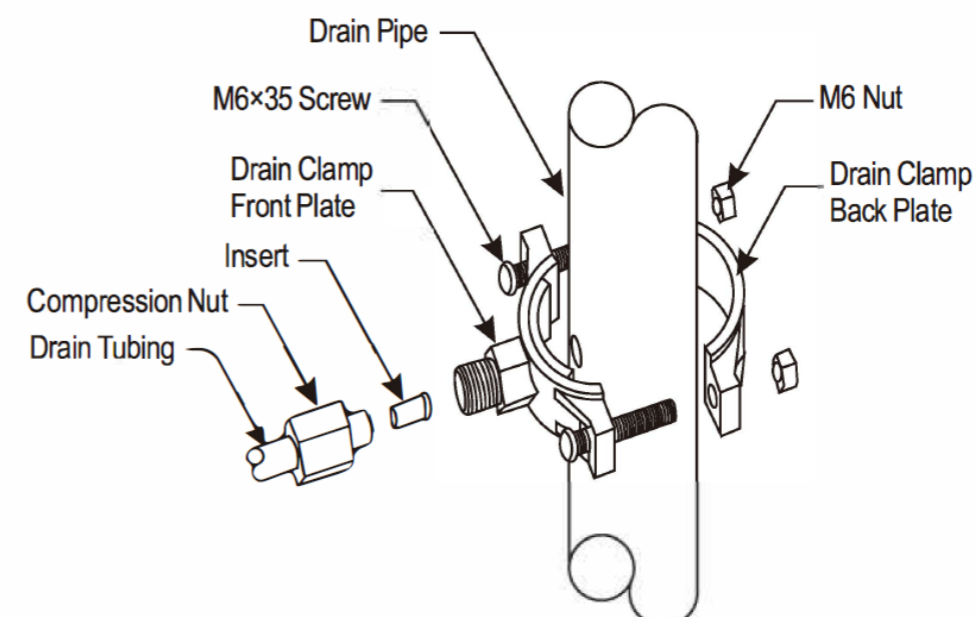

/ FEED WATER VALVE AND TEE FITTING

- Install Tee Fitting Valve shown below to your 15mm cold water pipe.
- Attach the grey plastic adapter to the male thread on the tee fitting.
- Apply sealant to olive as shown in right hand picture below.
- Ensure the compression fittings and the grey fitting are secured tight to seal
- Connect White Feed Water Tubing from unit to Feed Water Valve.

/ WARNING

Ensure chrome nut compression and grey plastic adapter are tight to seal.



/ NOTE

Use only a cold potable water supply as Feed Water, hot water will damage your unit. Softened Feed Water will extend the life of the RO Membrane.

/ PRESSURE TANK

Keep pressure tank within 10 feet of faucet.

If longer length of tubing is needed, use 3/8" tubing only to prevent pressure drop. Tank can weigh up to 30lbs when full, find firm and level flooring.

Install Ball Valve by screwing Valve on to Tank and apply Teflon tape to prevent leaking.

Connect **Yellow tubing** from post filter to Pressure Tank.

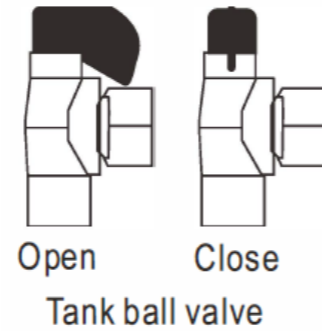

Quick Fitting

Install the water pipe

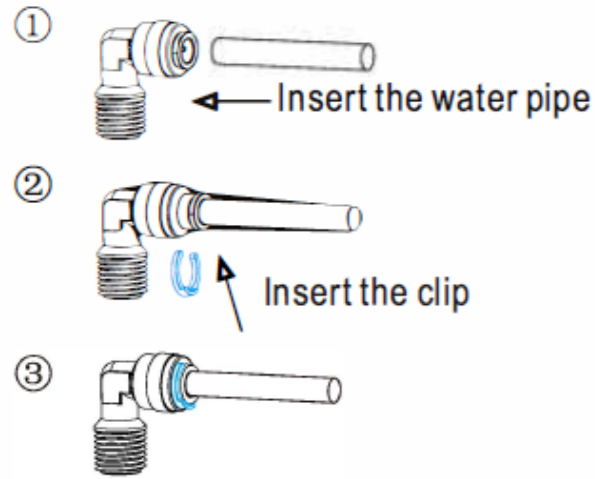

Pull out the water pipe

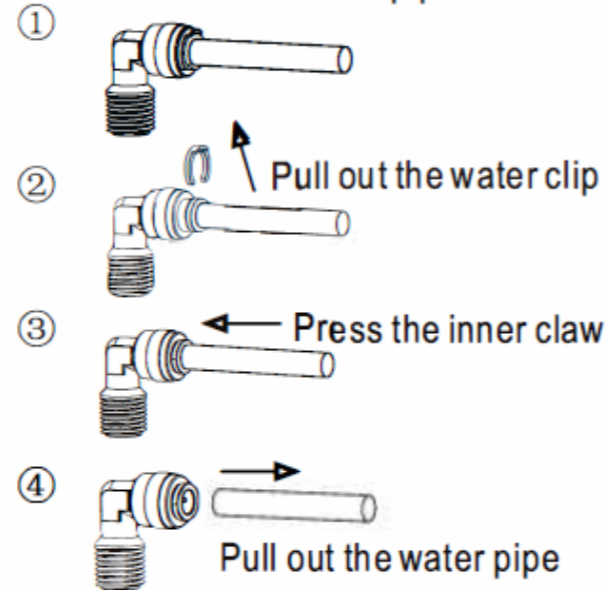

/ FAUCET INSTALLATION

/ WHERE TO PLACE YOUR FAUCET

The faucet should be placed in a convenient area near the sink tap. There should be a reasonable amount of space above and below the faucet mounting position to allow to connections to the RO unit.

There should be a 2" diameter area for the faucet to be mounted.

The thickness of mounting surface should not exceed 32mm.

Select a convenient location near your sink to place the faucet. Drill a hole 12mm in diameter into the counter top. Place washers, plates, seals and nuts in order as per diagram and tighten on the countertop. Screw the grey plastic adapter on the bottom of the faucet.

Attach the **Blue Pure Water tubing** to the grey plastic adapter on the bottom of faucet and connect tubing to unit.

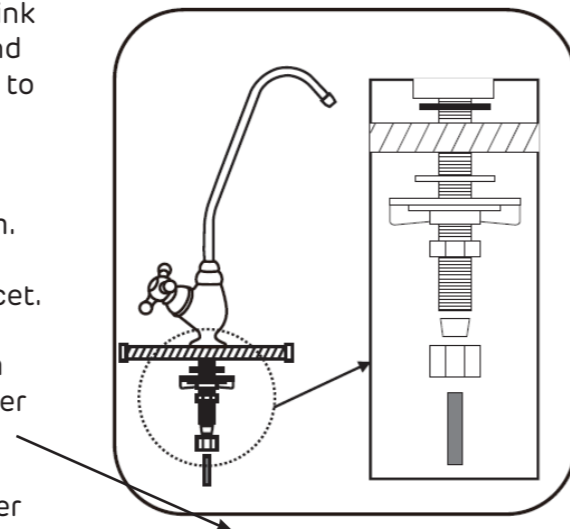

/ INSTALL PRE-FILTERS

- Remove Pre-Filters from packaging.

- Place filters in appropriate housings according to labels and install filter housing from right to left in the following order: PP, GAC, CTO.

- Tightening housings with wrench provided.

/ NOTE

RO membrane is not to be installed until after pre-filter flush has been complete.

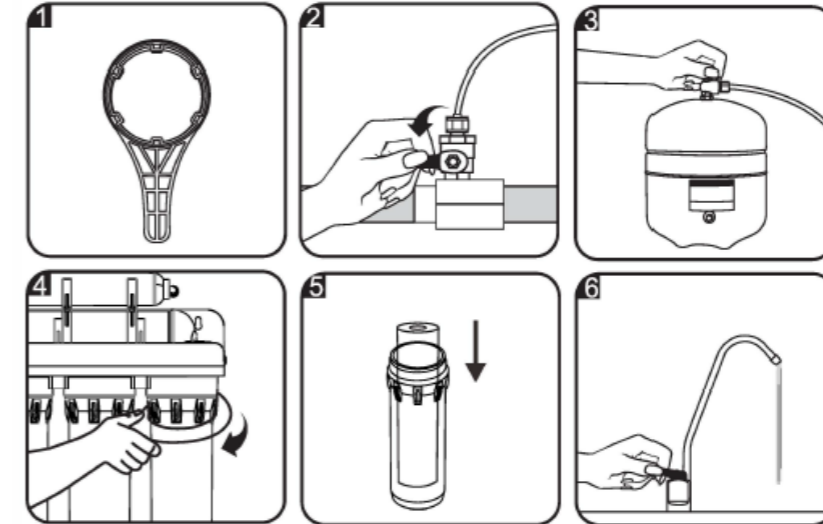

/ NOTE

When installing housings make sure housing is level and even to avoid leaking.

/ TANK INSTALLATION

- Hand tighten plastic.
- Shut-off valve to tank.

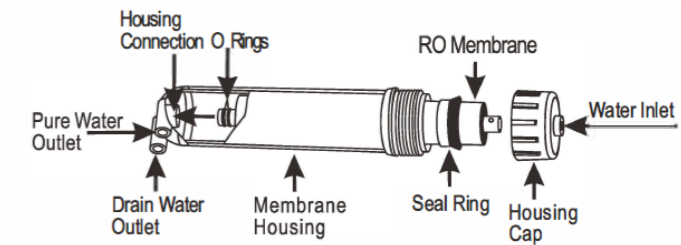
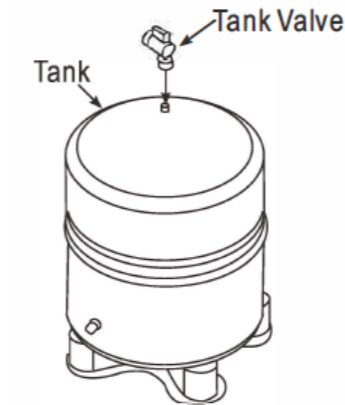

/ OPERATION AND MAINTENANCE

Pre-filter Flushing (initial setup, before installing RO Element)

Prepare system for operation by flushing pre-filters:

- Disconnect RO element inlet tube on element housing cap. Open water main and inlet valve and allow system to run through the 3 pre-filters.
- Discard output water into container or drain.
- Continue flushing until output water is visibly clean. Reconnect tube.

Note: Pump and membrane may be severely damaged if system is run without flushing pre-filters. Discard all water from flush, it is not suitable for use or consumption.

- After flushing pre-filters connect and open all valves.
- Wait approximately 2 minutes before opening faucet.
- Allow system to flush for first 10-15 minutes with faucet open. Do not use water from RO unit at this time.

/ RO MEMBRANE INSTALLATION

/ NOTE

Before proceeding with membrane element installation, please flush pre-filters thoroughly. (See previous step)

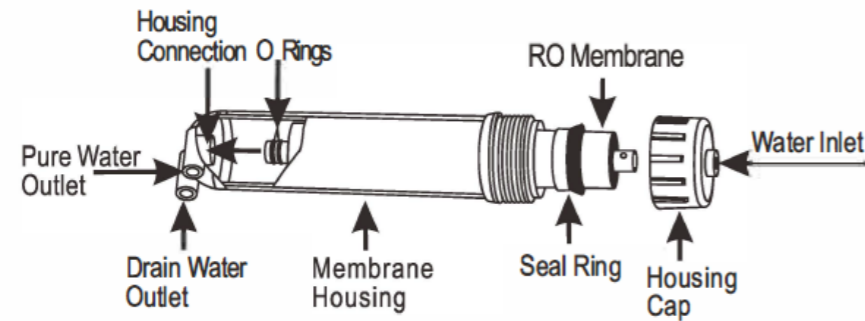

- Remove RO housing cap using wrench.
- Remove RO element from packaging.
- Insert RO element into housing with the small double O rings facing inward.
- Install membrane housing cap and tighten with wrench provided.

/ FLUSHING THE PRESSURE TANK

- After flushing the Pre-Filters, allow the unit to operate and fill the Pressure Tank.
- Tank will take approximately 3.5 hours to fill. Once tank is full, discharge Pressure Tank by leaving faucet open.
- Once Tank is completely empty, close faucet and allow tank to fill again. After the Pressure Tank has been flushed, the unit is ready for use.

/ FILTER MAINTENANCE

To ensure the unit operates at its optimum level, routine maintenance is required. The frequency of maintenance depends on the feed water quality and amount of system usage. The following are some guidelines for scheduled filter changes, keep in mind the frequency of filter changes may vary. If in doubt, contact your local dealer or service technician.

- Change all cartridges every 6 months.
- Change membrane as requested.

If you will be away or not using the unit for an extended period of time, please disconnect unit from power supply. If the unit has been shut down and not used for an extended period of time, perform the same flushing procedure as in the initial set up.

/ FILTER REPLACEMENT

- Close Feed Water Valve.
- Close Tank Ball Valve on Pressure Tank.
- Open Faucet and drain any remaining water from system.
- Disconnect quick connect filters.
- Replace filters, reconnect, and open valves.
- Perform pre-filter flush after filters have been changed

/ NOTE

Diagrams on how to connect using quick connect fittings can be found in the installation section.

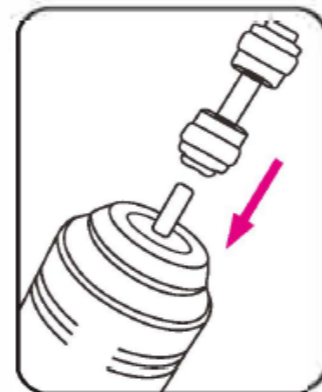

/ MEMBRANE REPLACEMENT

Close Feed Water Valve.

Close Tank Ball Valve on Pressure Tank.

- Open Faucet and drain any remaining water from system.
- Open membrane housing and remove used membrane.
- Follow the same procedure as RO membrane installation to replace RO membrane.

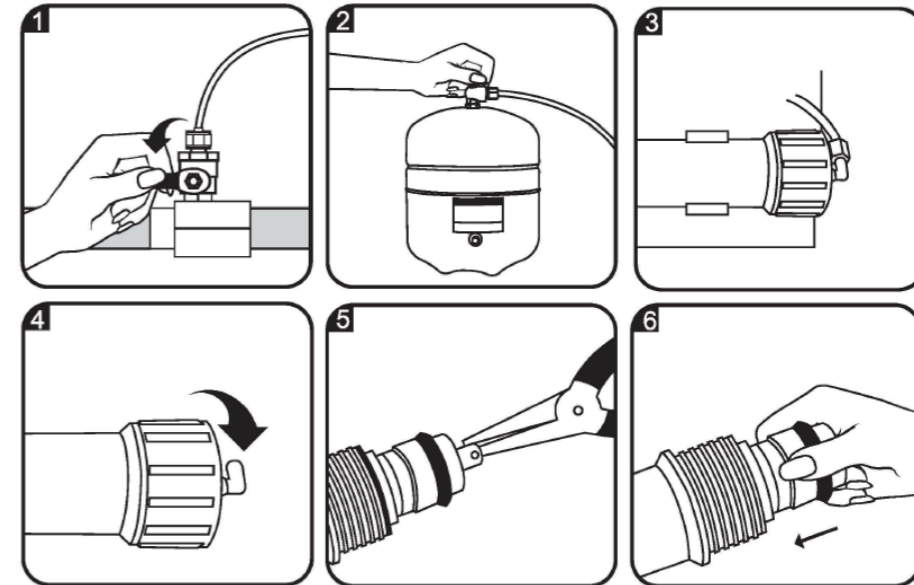

/ TROUBLESHOOTING

PROBLEM	CAUSE	SOLUTIONS
Milky colored water	√Air in system	○ Air in the system is a normal occurrence with initial startup of the RO system. This milky look will disappear during normal use within 1 to 2 weeks.
Noise from system	√Air gap faucet √Location of the drain saddle √Restriction in the drain line	○ Will disappear after system shut off ○ Relocate the drain to above water trap. ○ Blockage sometimes caused by debris from garbage disposal or dishwasher.
Small amount of water from RO drinking faucet	√System just starting up √Air pressure in the storage tank is low.	○ Normally it takes 2-3 hours to fill tank. Low water pressure and/or temperature can reduce production rate. ○ Add pressure to storage tank. The pressure should be 5 - 8 psi when the tank is empty.
Slow production or no water from RO drinking faucet.	√Low water pressure √Crimps in tubing √Clogged pre-filters √Fouled membrane	○ Add a booster pump ○ Make sure tubing is straight ○ Replace pre-filters ○ Replace membrane
Water taste or smell offensive	√Post carbon is depleted. √Fouled membrane √Sanitizer not flushed out	○ Replace post carbon. ○ Replace membrane. ○ Drain storage tank and refill it overnight.
No drain water	√Clogged flow restrictor	○ Replace flow restrictor.
Leaks	√Fittings are not tightened. √Twisted O-ring √Misalignment of hole in the drain saddle valves.	○ Tighten fittings as necessary. ○ Replace the O-ring. ○ Realign drain saddle valve.

/ SAFETY INSTRUCTIONS

This appliance is intended to operate and function as per the instructions in this manual. It is not designed to operate outside of the specifications listed and any attempt to do so or tamper with the unit can cause damage to the unit and/or bodily harm. This unit is not a toy, keep out of reach from small children. If the unit requires service or repair, please contact your local service technician or sales representative.

- Please ensure feed water temperature is over 4 °C. Using water below 4 °C can cause ice to form and damage the unit.
- Please ensure power source is correct before connecting unit. Incorrect voltage could result in damage to unit and/or fire hazard.
- Do not cause damage to or use unit if the power cord is damaged. A damaged power cord could cause an electrical shock or fire hazard. If power cord is damaged, unplug and discontinue use immediately.

/ DISCLAIMER

In case of special circumstances during installation, you need to use accessories not included in the packing list of this product. Consumers are asked to purchase quality-guaranteed accessories through regular channels.

Monarch Water is not responsible for the quality of non-original accessories because of the quality problems of the accessories purchased by consumers. Monarch Water assumes no responsibility for any water leakage accident.

/ REGULAR MAINTENANCE

Please ensure you change your filters when recommend. Failure to change your filters regularly may invalidate your warranty. Regularly check the TDS level of your output water.

Ensure that you change your Reverse Osmosis Membrane when recommend or when the TDS level starts to rise.

For best performance, supply unit with softened water, as this will achieve maximum life expectancy of the membrane.

TO ORDER SPARE PARTS

Please contact your dealer for more information.

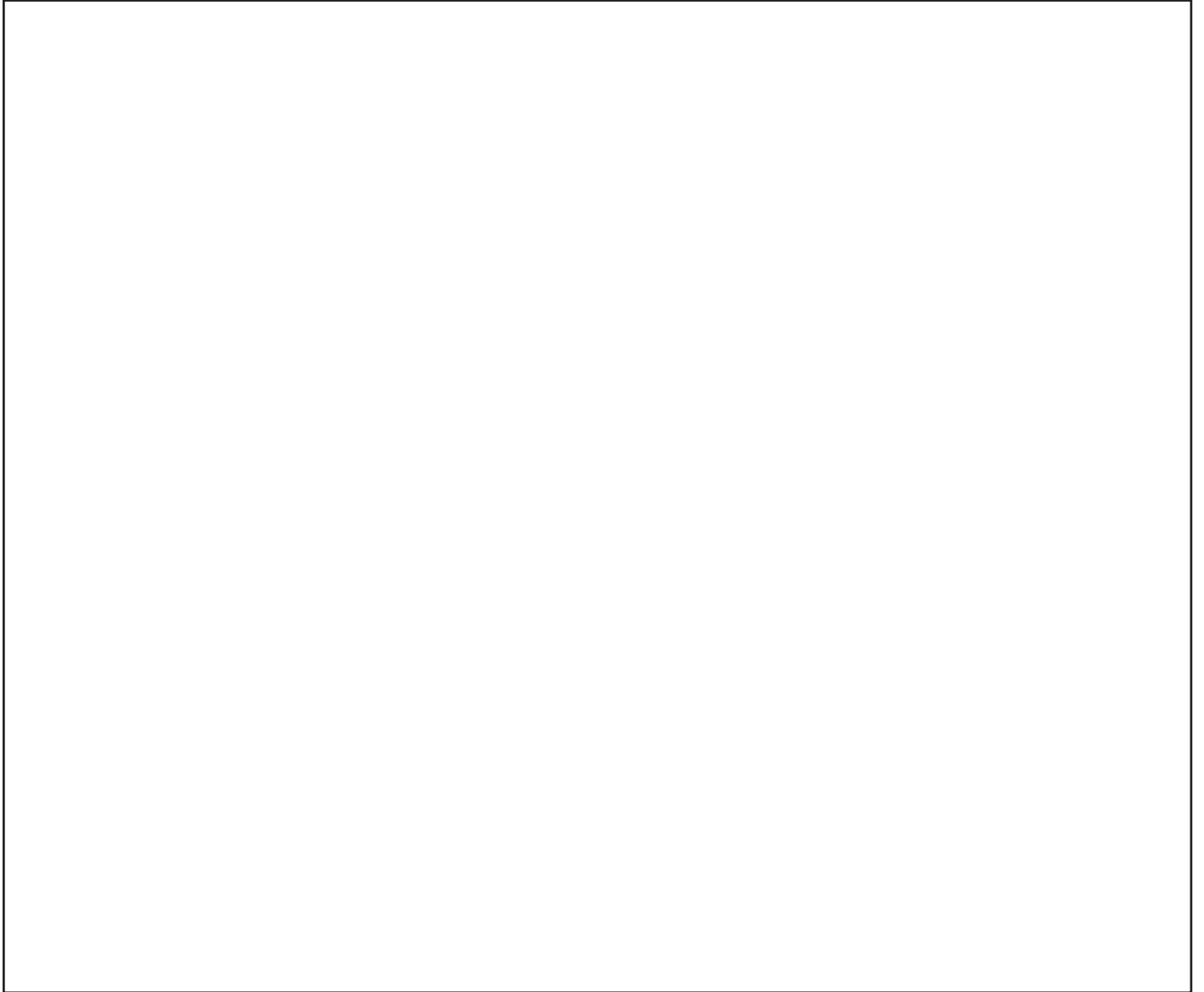

+ 44 (0) 1986 784759
monarchwater.co.uk
info@monarchwater.co.uk

