

 MONARCH WATER

AQUARIUS

INSTALL GUIDE
BOILING WATER TAP

WELLBEING™



EVOLUTION SINCE 1964

IMPORTANT READ BEFORE COMMENCING INSTALLATION

Thank you for purchasing a Monarch Water boiling kettle tap. This product has been designed and manufactured to the very highest quality standards. This guide explains how to install a new Monarch Water kettle tap boiling water appliance.

/ WARNING

DO NOT ATTEMPT TO INSTALL THIS PRODUCT WITHOUT REFERENCE TO THIS GUIDE. FOR THE PRODUCT TO FUNCTION CORRECTLY IT MUST BE INSTALLED STRICTLY IN ACCORDANCE WITH THESE INSTRUCTIONS.

PARTICULAR ATTENTION MUST BE PAID TO ENSURING THAT THE WATER PRESSURE, WATER FLOW AND ELECTRICAL SUPPLY ARE WITHIN THE STATED PARAMETERS. THE MANUFACTURER RESERVES THE RIGHT TO RECOVER ANY COSTS INCURRED AS A CONSEQUENCE OF INCORRECT INSTALLATION.

/ SAFETY

/ NOTE

Boiling water is potentially dangerous. It is the responsibility of the owner to take sensible precautions when operating the boiling water function of the Monarch boiling kettle tap and to instruct all users to operate it safely. It is not recommended to allow children, infants and toddlers the use of these taps.

If a new electrical power supply is required you must seek the services of a qualified electrician.

The boiler should be plugged into a socket that has been installed in compliance with local wiring regulations - seek the advice of a qualified electrician if in doubt. It is advisable to check the circuit to establish whether or not the addition of a Monarch boiling kettle tap will overload the circuit. Important Note: The boiler should not be fitted on the same electrical supply line with other appliances that require a constant power supply such as a fridge/freezer.

The boiler is fitted with an electrical lead terminating in a fused plug for connection to the 230 volt 13 amp electricity supply. It is important to use a socket with a built in switch and position it to provide convenient access to switch off the boiler.

The electrical lead or plug must not be modified in any way.

Turn off the mains water supply before commencing installation.

Never lift the boiler by any of its hoses or pipes.

The power to the boiler must only be switched on once the installation is complete and the tank is full of water.

Always turn off the electricity supply to the boiler before you close the mains stop valve. Restore power to the boiler after the mains stop valve has been opened.

Potentially vulnerable users must be instructed on how to operate the boiling water function safely by a responsible adult.

/ A. Product Photo

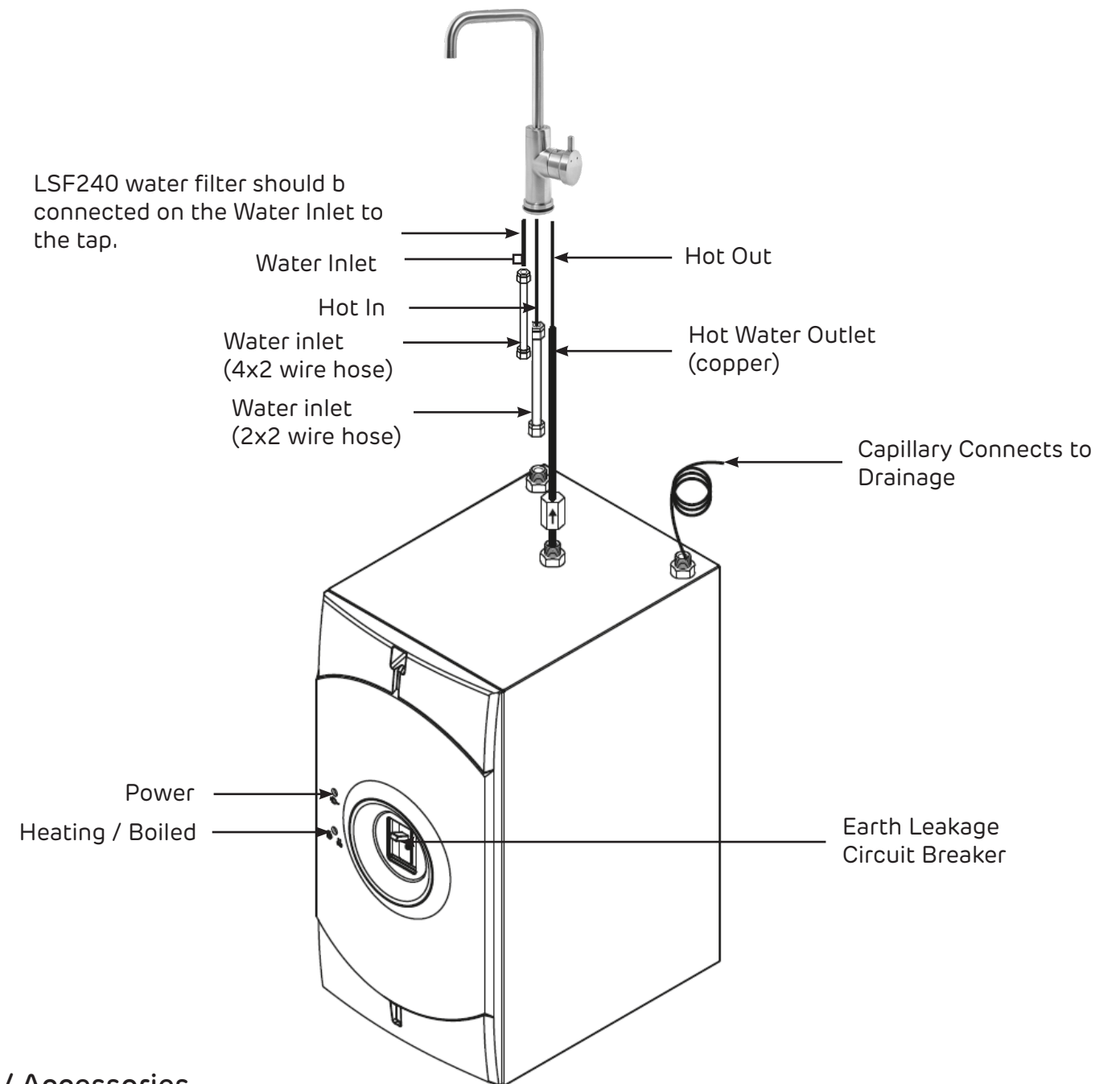

/ Accessories

- Copper pipe
- 2 x 2 wire hose
- 4 x 2 wire hose
- Adapter for Hot water outlet Adapter for Hot water inlet steam released pipe
- LSF240 Filter

/ Product Specification

- Voltage: 230V
- Electric Power: 750W
- Capacity: 4L
- Water inlet: pre filtered water
- Weight: 4.2kg
- Hot water temperature: 98°C
- Dimensions: H390 x W180 x D240mm
- monarchwater.co.uk

Arrow is direction of water outlet

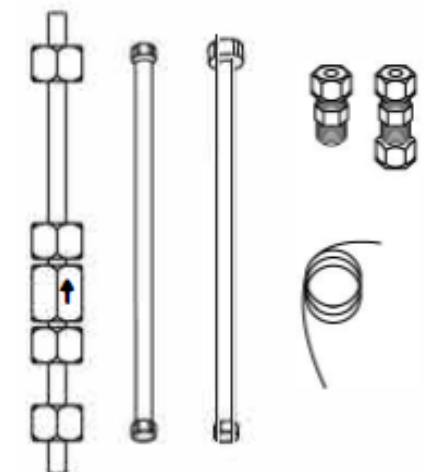

/ B. Accessory Assembly

1. Feed water connector <only for R.O system>
2. Ball valve <only for R.O system>
3. Feed water hose
4. Feed water adaptor

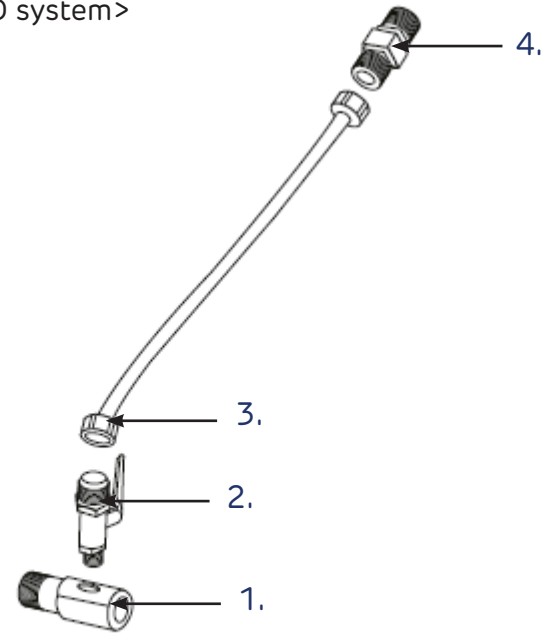

/ C. Connect to water source

1. Connect to faucet

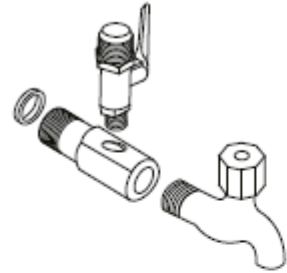

2. Connect to adapter

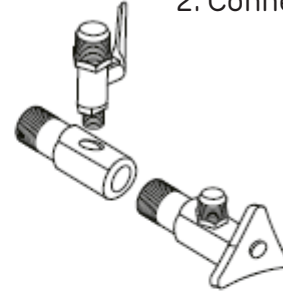

3. Connect to cold / hot mixed faucet

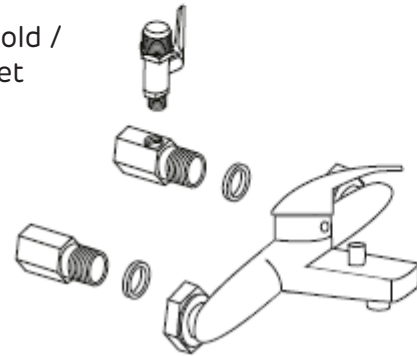

/ C. Installation Notice

1. Install the unit far from fire, combustibles and chemicals
2. Do not install the water dispenser outdoors
3. There should be an available ground drain hole within 2 metres around the unit
4. The water source should be pre-filtered
5. Please install a water valve on the water inlet tube for maintenance
6. Please install the ground wire for safety
7. Suitable water pressure 22-87psi

/ D. Water and power

Before installation -

- 1a. Please plug in the correct voltage and power according to the specification sticker
- 1b. if there is no ground hole on the power socket, please install the ground wire for safety
- 1c. Please install additional ground wire for safety in case there is no ground connection available on the outlet
- 1d. Still hose connects to water inlet. 1/4 copper tube connects to water outlet

/ After installation

- 2a. After finishing the plumbing and installation, please make sure the earth leakage circuit breaker is in 'off' position (to prevent damage to the heating tube if it is on and there is no water input).
- 2b. Once the water outlet can supply the water, please adjust the earth leakage circuit breaker to "ON", this will then heat the water.

/ E. Operation notice

1. If the unit is shut down for more than half an hour, the hot tank will sound while heating due to thermal expansion and contraction principle.
2. Before starting to use the dispenser, please be sure to boil the water firstly, then flow out of the water spout to clean all tanks and pipes inside.
3. Please prohibit children, infants and toddlers from using the water dispenser to prevent scalding
4. In the case of any problems with the water dispenser, please turn off power and water source and call 01986 784759 for support.
5. If the operation of the water dispenser is broken or you are planning to leave the premises for an extended period (2+ days) it is a sensible precaution to turn off both the electricity supply and the water supply to your system. Upon your return, turn on water and power supply, and flush for 5 minutes before reusing.
6. Do not directly wash the unit with water or wet rags to prevent rust or internal parts becoming damaged by any water damage.
7. Please renew the soft tube regularly (1-2 years). Over aging tubes may leak.

/ F. Trouble Shooting

No water flows out

Possible reason	Action
Water source suspended	Wait for water supply to be restored

No power

Possible reason	Action
Power failure	Check the power source or any fuse problem on electric equipment
Earth leakage circuit breaker cut the power	Leakage of electricity. Please cut the power and water source, then call for service

Hot water temperature cannot rise

Possible reason	Action
The heating tube is damaged	Please cut the power and water source, then call for service

/ G. The standard method of adjusting the relief valve

1. Turn off the power
 2. Dispense the hot water for five seconds from the faucet
 3. Loosen the relief valve by turning counterclockwise until water is ejected from the steam
 4. Tighten the relief valve slowly by turning clockwise, until the steam is released and no water comes out. Then tighten to 180°c
- monarchwater.co.uk

+ 44 (0) 1986 784759
monarchwater.co.uk
info@monarchwater.co.uk

