

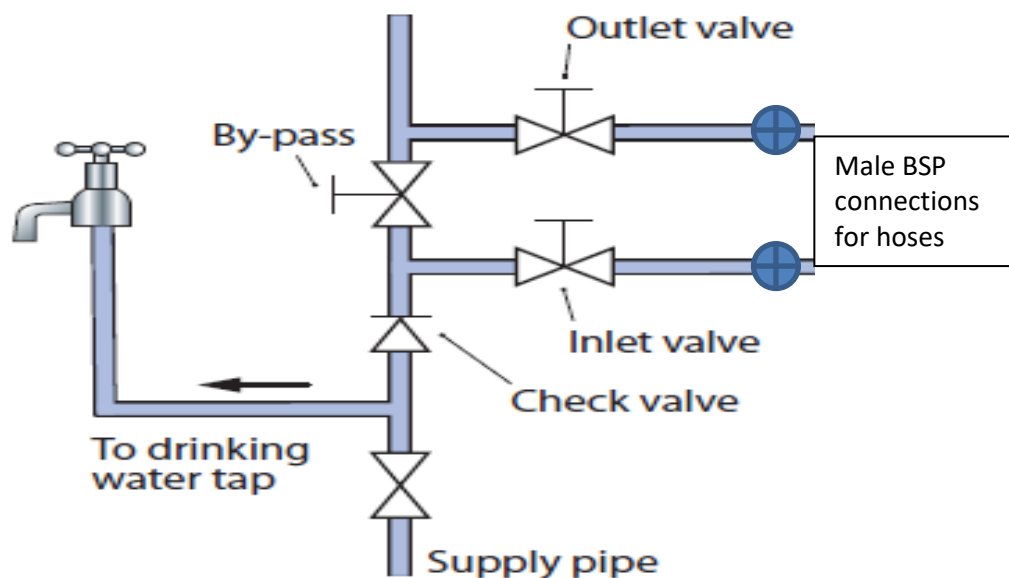

MONARCH WATER CIS Model No

1. Form 3 valve bypass as shown below. Note that check valve must be of double check valve construction. Terminate copper inlet and outlet lines with male BSP threaded connections for hose connection.

Tip of the day: Connect loosely the hoses to the inlet/outlet connections and take other ends of hoses to proposed connection point of the copper/PVC mains pipework, allowing tolerance for movement when connecting. This ensures hoses fit neatly without sharp kinks/bends that will affect the flow rates.



2. Connect inlet hose to bottom connection on Scaleout using fibre washers to seal.
3. Connect other end of inlet hose to male BSP thread on inlet pipework, again using fibre washer to seal.
4. Connect outlet hose to top connection on Scaleout using fibre washer to seal.
5. Connect other end of outlet hose to male BSP thread on outlet pipework, again using fibre washer to seal.
6. Open inlet valve slowly to approx. 25% opening and to pressurise unit.
7. Open outlet valve slowly and allow water to run to immediate service or sample tap.
8. After approx. 10 minutes, close service/sample tap and check for leaks.
9. Open inlet valve fully.
10. Open bypass valve and close outlet valve.
11. Allow 20 minutes for unit to rest with water inlet open.
12. After 20 minutes close bypass valve and open outlet valve.
13. Run water slowly from immediate service tap for 20 minutes to rinse media. Close tap.
14. You have now finalised the installation.
15. Check that bypass is closed and both inlet and outlet valves are open.

Suppliers to H.M. the Queens Estate at Sandringham

Premium CIS Scaleout Systems.



Models up to inc CIS844:

Connections are 1" MBSP.

These connections can be converted to 3/4" MBSP on request – order code: SK17034MBSP

Models CIS964 & CIS1084:

The Male BSP connection set has already been made for you.

Simply insert large fibre washer onto shoulder within female thread on main connection head, then tighten inlet and outlet connectors up to fibre washer. Tighten to seal.

If sealant is to be used together with the fibre washers, Monarch recommends Loctite SI 5331 food grade sealant. Important: Insert fibre washer first, then apply sealant to both female and male threads before assembly.

Models up to CIS844 come fully assembled with standard set up (no pre/post filters or bypass valve).

Models CIS964 and CIS1084 please see the notes above.

It is recommended to install bypass valve set on the pipework as per overleaf.

If Post Filters are required they are to be installed on the outlet of the unit and plumbed in solid pipework back to the mains pipework.

If carbon Pre Filters are required they are to be installed on the inlet of the unit and again plumbed in solid pipework back to the mains pipework.

Post Filter cartridge is to be changed when pressure loss is too much for the application. Maximum life in the field is 6 months per cartridge.

Pre Filter cartridge is to be changed when pressure loss is too much for the application. Maximum life in the field is 6 months per cartridge or when manufacturer's capacity is reached.

Scaleout resin is to be changed every 2 years regardless of use.

See Scaleout Performance Guide below for full operating conditions requirements.

Suppliers to H.M. the Queens Estate at Sandringham

Monarch Water Ltd, Halesworth Road, Bramfield, Suffolk, IP19 9HP

Tel: 01986 784759 Fax: 01986 784769 Email: sales@monarchwater.co.uk Web: www.monarchwater.co.uk

Post Filter Specification to be attached to outlet connections.

The CISH34 has ¾" nipples c/w 'o' rings to seal.

The CISH44 has 1" nipples c/w fibre washers. Fibre washers are to be inserted inside filters female BSP thread up to shoulder edge. Nipples are to be screwed in to form seal against shoulder edge.

The CISH64 has a 1.5" FBSP thread that is to be sealed using LOCTITE SI-5331 sealant.

Hose Specification

All hoses are extra and are stainless with chromed brass nuts with the following specification and limitations;

Pair Maxflow hoses – ¾" FBSP elbow/straight, 80C, 60cm long with fibre washer seal.

Pair Ultraflow hoses – 1" FBSP elbow/straight, 80C, 60cm long with fibre washer seal.

Single 1.5" Hose – 1.5" FBSP straight/straight, 60C, 100cm long with fibre washer seal.

Single 2" Hose – 2" FBSP straight/straight, 60C, 100cm long with fibre washer seal.

Single 3" Hose – 3" FBSP straight/straight, 60C, 125cm long with fibre washer seal.

Duplex connection kits;

1.5" duplex connection kit to convert to 1.5" MBSP.

2" duplex connection kit to convert to 2" MBSP.

3" duplex connection kit to convert to 3" MBSP.

Flow rates;

A simplex 2" system will give 78% more flow rate than a 1.5" simplex system.

A 1.5" duplex system will give 12% more flow rate than a single 2" simplex system.

A 2" duplex system will give 12% lower flow rate than a single 3" simplex system.

Scaleout Specification

Specification:

| Model | MBSP Connection Size | Peak intermittent flow – m3hr |
|---------|----------------------|-------------------------------|
| CIS144 | 1" | 1 |
| CIS244 | 1" | 2 |
| CIS344 | 1" | 3 |
| CIS444 | 1" | 4 |
| CIS544 | 1" | 5 |
| CIS644 | 1" | 6 |
| CIS744 | 1" | 7 |
| CIS864 | 1.5" | 8 |
| CIS964 | 1.5" | 9 |
| CIS1084 | 2" | 10 |

Suppliers to H.M. the Queens Estate at Sandringham

The Monarch Scaleout is fully covered by a retrospective parts and 12 month labour guarantee for installation within the hard water regions of mainland England as detailed on Monarchs National Service Coverage Area, from date of original purchase.

Installations outside this area are automatically covered by parts only 'exchange' warranty as determined the Coverage Area – details available on request.

Definition and example of 'Retrospective with a 2 year resin warranty':

If the resin fails at 20 months, then new resin will be replaced under the 2 year guarantee but charged at 20/24ths of the replacement resin cost, plus delivery, plus VAT.

Resin Guarantees:

S models and all CIS models @ 2 years

Performance Guarantee: The Monarch Scaleout may provide a soft scale/white residue environment for the appliance/property it is protecting. Any soft scale/white residue created, to be removed during normal maintenance procedure. Hard scale will not form as long as the unit's expectations are not exceeded, namely;

1. The Scaleout is not a water softener. It exchanges Calcium ions into calcium crystals and the water remains hard. When a Post Filter is used, crystals will adhere themselves to the Post Filters internal cartridge, which is to be changed annually (or before in very hard water areas). However some will pass through as this is part of the descaling process. These will materialise as a residue/dust if the water is allowed to evaporate i.e. stainless steel sinks. For best results it is recommended to wipe away with a damp cloth before they appear.

2. Helping your kettle last longer: Your kettle will continue to have an amount of soft scale/white residue, but the level can be kept to a minimum by running the tap for 5-10 seconds prior to filling. Additionally, it is recommended to empty the kettle of any water left over from the previous use. When emptying, you may notice scale flakes and possibly 'milky' water too. This is normal and proof that the Scaleout is working at optimum performance. Flakes are caused by taking the water to boiling point and will not happen elsewhere throughout your system.

3. Toilets, Showers, Shower cubicle/screen, Taps etc: Because there is no direct flow across these surfaces, other than water splashing, the old scale may need to be removed with a scale remover. Any new accumulation will deposit as a soft scale and should be periodically removed. For best results, wipe away water before being allowed to evaporate.

4. Existing scale – Scaleout water will immediately begin to de-scale your pipes and appliances. Your hot water cylinder will take longer to de-scale than your pipe work; in some cases 12-18 months; therefore you may notice different levels of Scaleout water for some time whilst the system is de-scaling. This is particularly noticeable in your bath and shower.

Suppliers to H.M. the Queens Estate at Sandringham

Monarch Water Ltd, Halesworth Road, Bramfield, Suffolk, IP19 9HP

Tel: 01986 784759 Fax: 01986 784769 Email: sales@monarchwater.co.uk Web: www.monarchwater.co.uk

5. Dishwashers – On most installations the dishwasher is to be connected to the Scaleout water. We recommend that you continue to add a small amount of salt to the appliance as before, as this helps the resin holder in the appliance stay clean.

We do not however recommend that crystal glass; solid silver or silver plated items are washed in your dishwasher as etching may occur. Less dishwasher liquid may be required and in certain cases this will also apply to rinse aid. For best results use a natural soap detergent/cleaning agent. On dishwashers connected to untreated water, you should continue to put salt into the dish washers own softener. It will help if your dishwasher could be de-scaled prior to the installation of the Scaleout. This would also apply to your shower cubicle too. For best results a phosphate free and pH neutral (pH = 7) dish washing detergent is strongly recommended.

6. Scaleout water will become available throughout your system in varying time spans. Conventional systems (tanks in your roof) will take anything from 4-10 days, whilst mains fed Pressurised Systems will give treated water within 2-3 days.

7. Scaleout water will have no adverse effect in your heating system. In every case a corrosion inhibitor such as Sentinel X100 must be used. Any dosing chemicals not manufactured by Watch GmbH, Germany must be added to the system after the Scaleout point of installation, as the effect of other dosing chemicals on the Scaleout media is unknown.

8. Bath and shower surfaces will become smoother – be careful, in particular the young and infirm – why not buy a bath mat?

9. If possible look to use a pure soap powder as this will help give optimum results.

10. Outside Tap – It is recommended to leave your outside tap on mains water. Additionally, in the wintertime we recommend that this tap is isolated via an internal valve to prevent freezing.

11. Where a Scaleout is installed to protect a boiler with a blow down, the blow-down must be installed at the bottom of the boiler to allow crystal exit during blow-down.

12. IMPORTANT: Where a Scaleout is installed on a new copper main, it is recommended to place the unit on bypass for approx. 6 weeks to allow the copper to passivate as copper ions that leach into the water supply can damage the Scaleout resin.

The Scaleouts performance will be affected by the quality of the incoming water supply as other metals in the water may affect the resin beads and reduce their performance. This is very rare as mains water in the UK is generally clean. We do not recommend non mains water as a supply to the Scaleout.

Ref: Monarch Scaleout Performance Guide

Parameters to consider for the operation:

- a. Min – Max Operating pressure 1.5 – 8 bar. A 5 bar pressure limiting valve is recommended when daytime pressure exceeds 3.5 bar daytime pressure.
- b. Incoming Water Temperature 4 – 50°C
- c. pH 6.5 – 9.5
- d. Max Iron content 0.3 mg/l
- e. Max Manganese content 0.05 mg/l
- f. Max Copper content 0.3 mg/l
- g. Oil, Grease & H₂S Free
- h. Trace of metals as per Iron, Manganese, Copper, Lead, Zinc etc. will be absorbed by the Scaleout media on its catalytic surface bringing the functionality to an end. It changes the colour of the media. See Point 12 on previous page.
- i. Studies showed it's also possible that the Scaleout media changes colour due to a food grade dye leaching from the container tank made of Polyethylene.
- j. Do not use where water is microbiologically unsafe or with water of unknown quality without adequate disinfection before or after the unit.
- k. Anionic Scaling: Scaleout is designed to neutralize calcium and magnesium carbonate hardness which is the major reason of scaling. Scaleout cannot treat anionic water hardness which happens due to the presence of sulphates, phosphates, nitrates etc. If scale build up is noted after Scaleout installation it is highly possible that it is anionic scale. Anionic scale will not dissolve in vinegar and is very hard to remove. In such a case it is recommended to use dosing chemicals such as ISOFT DW or ISOFT which is best suitable for drinking water applications.
- l. Minimum contact time as determined by the models vessel size with water flowing no faster than 1 bed volume of the vessel per minute i.e. 1054 vessel with 60 litre capacity equates to 60 lpm maximum flow. This figure can be increased by 10% for intermittent bursts of peak flow for no longer than 1 minute.
- m. Minimum water pressure of 1.5 bar dynamic pressure.

Ref: Monarch Scaleout Performance Guide

- n. Minimum flow rate equal to 10% of resin vessel per minute i.e. 1054 vessel with 60 litre capacity equates to $60 \times 10\%$ equals minimum flow rate of 6 litres per minute to get bed lift to activate resin beads.
- o. A carbon pre-filter is recommended to protect the unit from levels of chlorine above 2 ppm that can affect the performance of the resin beads.
- p. Sediment pre-filtration is required to protect the unit where evidence of sand, silt and sediment has been or is likely to be evident.
- q. A water hardness test must be carried out prior to installation. For applications over 450ppm, a Plus (+) model is to be used.
- r. A post filter is recommended in applications where aesthetics are important.
- s. When sizing units, peak flow must be taken into consideration to prevent 'piston effect' of the resin*

**Piston effect is caused by high water flow moving the resin en-masse to the top of the vessel therefore preventing resin fluidisation and creation of crystals.*

